

14

INSTALACIÓN DE LAS PUERTAS
DOOR INSTALLATION

RTA[®]
m u e b l e s

INSTRUCCIONES DE ENSAMBLE
ASSEMBLY INSTRUCTIONS

UBICAR EL ENTREPAÑO
MÓVIL / PLACE THE
MOBILE SHELF

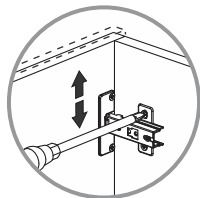
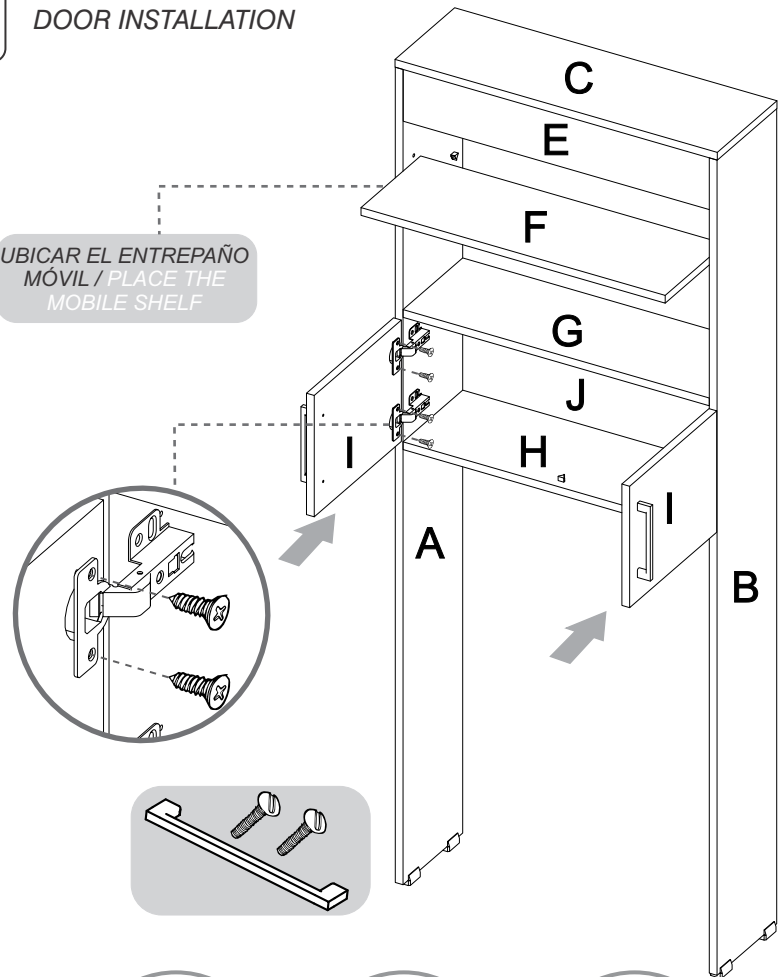

AJUSTE DE ALTURA
/ HEIGHT
ADJUSTMENT

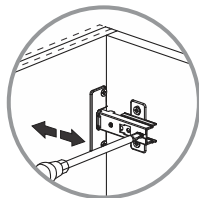

AJUSTE DE
PROFUNDIDAD
/ DEPTH
ADJUSTMENT

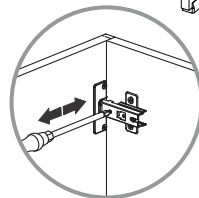

AJUSTE LATERAL
/ LATERAL
ADJUSTMENT



Al finalizar el ajuste, cubra
las cajas con las tapas
adhesivas / After tightening all
the panels, cover the minifix
cams with the adhesive caps.



Al terminar de armar, desprenda
los adhesivos (en caso de que
queden residuos de pegamento,
limpie la superficie con alcohol) /
After finishing the assembly, take off
the adhesives. (In case of glue
residues, wipe them with alcohol)

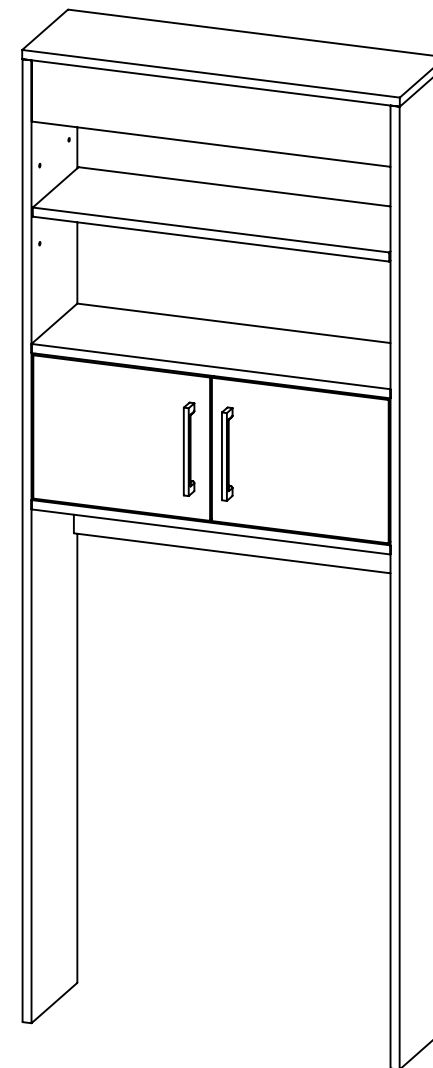

Alto/ Height: 160 cm / 63 in
Ancho/ Width: 62,4 cm / 24,56 in
Fondo/ Depth: 20,3 cm / 8 in

LOTE No: _____

By: RTA[®] TEL (572) 691 17 00
m u e b l e s PBX (572) 695 91 81
CALI - COLOMBIA
www.rta.com.co

AHORRADOR DE ESPACIO
MADRID

/Madrid Space Saver

RECOMENDACIONES IMPORTANTES KEY RECOMMENDATIONS

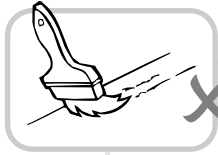

NO pinte el mueble /
Do not paint the
furniture.



NO mojar o ubicar
a la intemperie /
Do not expose to rain
or direct sun.

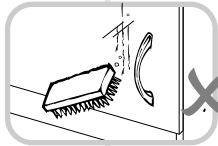
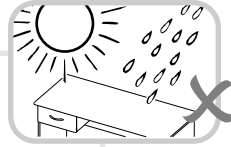

NO lavar las manijas o
tiraderas con jabones o
elementos abrasivos /
Do not wash handles or
drawers with soap or
abrasives.

NO sobrecargue el mueble.
no exceda el peso de 30 kilos
para gabinetes de cocina /
Do not overload the cabinet.
Weight max. 66lbs
for kitchen cabinets.

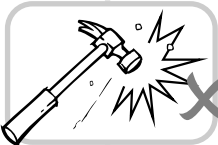

NO golpear ni martillar
el mueble (hágalo sólo
donde se indique) /
Do not hit or hammer
the furniture (just do it
where is indicated).

NO permita que los niños
manipulen el mueble, puede
voltearse y lastimarlos /
Do not allow children to
handle the cabinets or
drawers, they could get hurt.

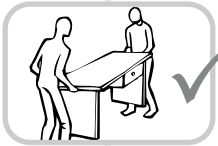

SIEMPRE levante el
mueble entre dos
personas, NO lo arrastre /
Do not drag the furniture.
Lift it between two people.

Limpie con paño seco,
/ Clean with a dry cloth.



HERRAJES BÁSICOS PARA MUEBLES RTA BASIC HARDWARE FOR RTA FURNITURE

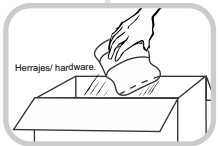

1. Abrir la caja del mueble
y buscar la bolsa con los
herrajes / Open the box
and look for the hardware
bag.

3. Separe los herrajes para
facilitar su identificación
durante el armado /
Separate hardware for easy
identification during
assembly.

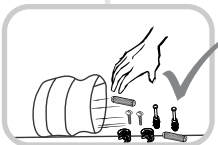
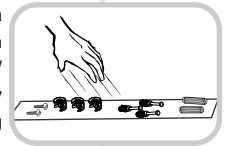

2. Abrir el paquete y
comprobar que el
contenido de las piezas es
correcto / Open the
package and verify that
the content of the pieces
is correct.

4. Arme el mueble en un lugar
limpio y en una superficie
plana / RTA furniture
must be assembled
in a clean place and on
a flat surface.

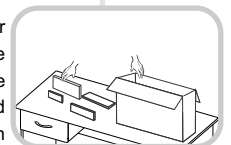

VOLTEAR EL MUEBLE CUIDADOSAMENTE
/ CAREFULLY FLIP THE CABINET



PARA INSTALAR A PARED
WALL INSTALLATION

13



* Herramientas
NO incluidas/
Tools not
included

Utilizar una broca
de 5/16" para hacer
las perforaciones
en el muro/
Use a 5/16" drill bit
to drill the wall.

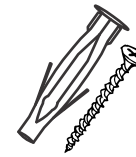

Tornillo 2 1/2" +
Chazo Mariposa/
Drywall Screw +
Wall Anchor

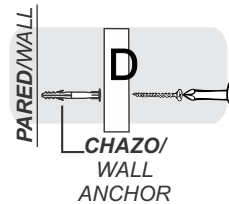

Tapar las perforaciones
que quedan expuestas con
tapas minifix/ Cover the
exposed drillings with
minifix covers.

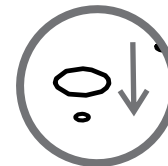

* Centímetros - Pulgadas / Centimeters - Inches

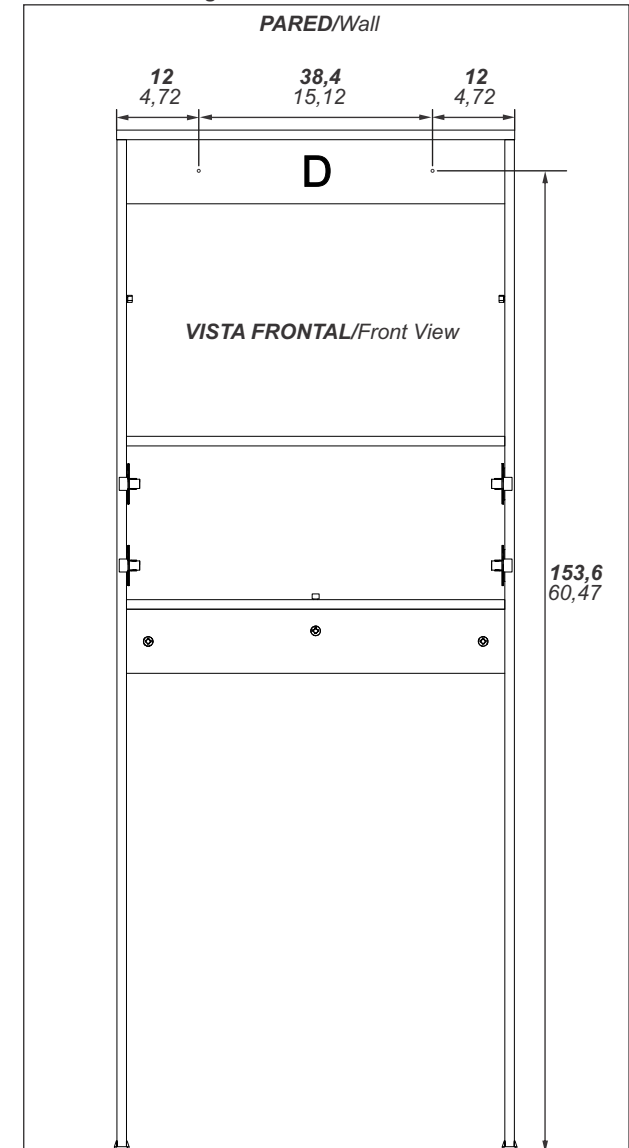

12

VOLTEAR EL MUEBLE CUIDADOSAMENTE PARA ENSAMBLAR EL FONDO
/ CAREFULLY FLIP THE CABINET TO ASSEMBLE THE BACK PANEL

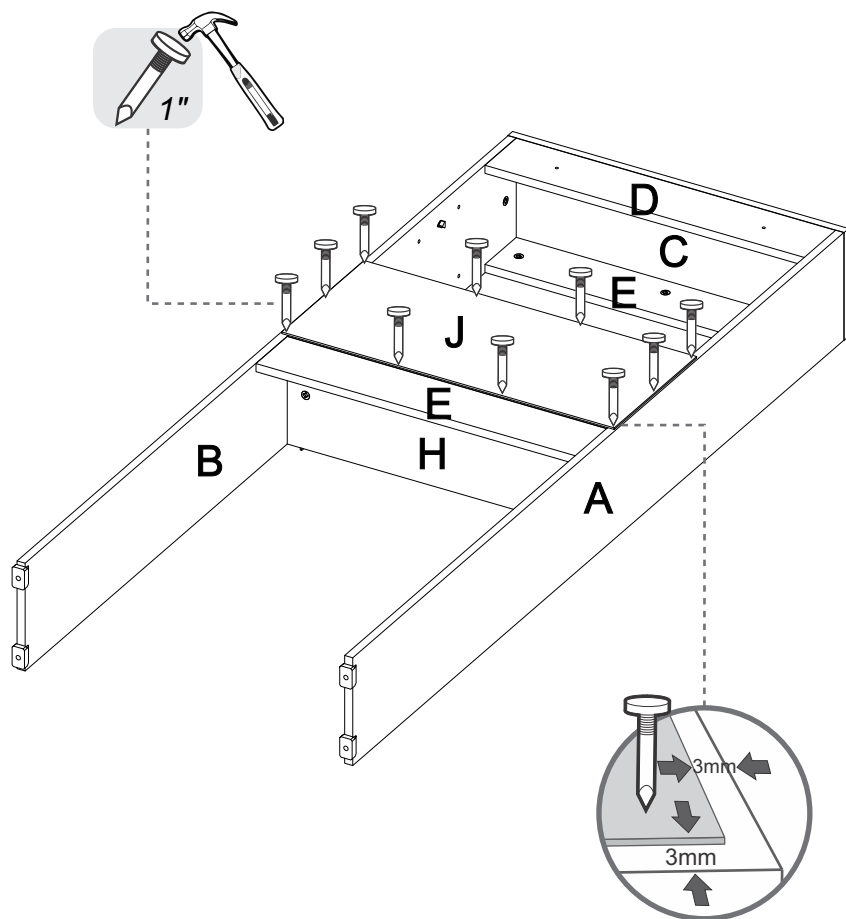

RECOMENDACIONES DE ENSAMBLE / ASSEMBLY RECOMMENDATIONS

El buen funcionamiento del mueble depende de un adecuado ensamblaje
An excellent furniture's performance relies on a solid and a suitable assembly.

MINIFIX / CONNECTOR - DOWELS

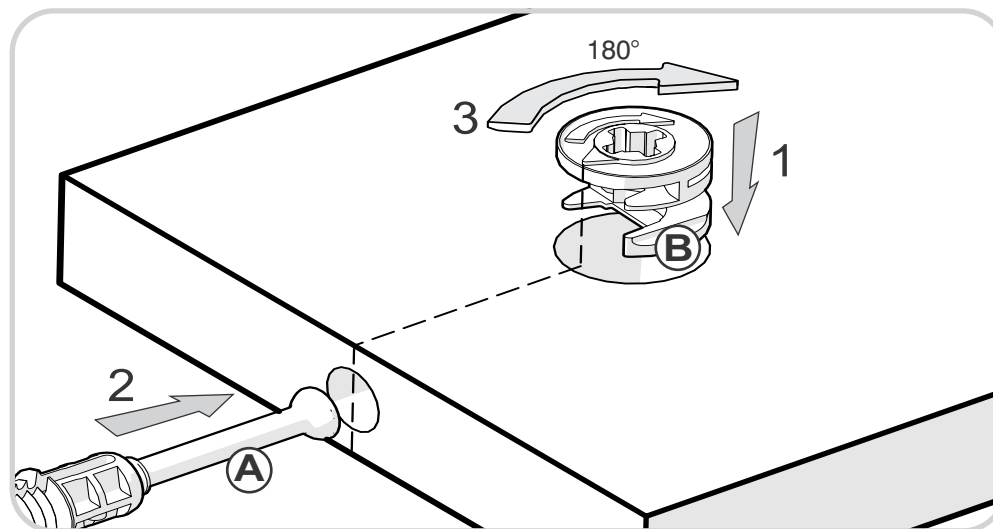

Sistema de unión compuesto por un perno (A) y una caja minifix (B).

(1) Se inserta la caja minifix dentro de la perforación ubicada en la cara de la pieza, la flecha debe apuntar siempre a la dirección de la perforación por donde entrará el perno.

(2) Se debe insertar el perno por su parte plástica en las perforaciones que se indiquen, luego se inserta la punta metálica en la perforación para que su cabeza quede al interior de la caja minifix.

(3) Girar la caja minifix 180° para apretar las dos piezas.

It's a fitting system made of a spreading bolt (A) and a minifix cam (B).

(1) Insert the minifix cam in the hole placed in the face of the panel with the arrow pointing towards the hole where the bolt will fit.

(2) Insert the bolt with its plastic base in the shown holes, then insert the metallic bolt head in the holes so it fits inside the minifix cam.

(3) Tight the panels by turning the minifix cam 180°.

TARUGOS O TAQUETES / FLUTED DOWEL PIN

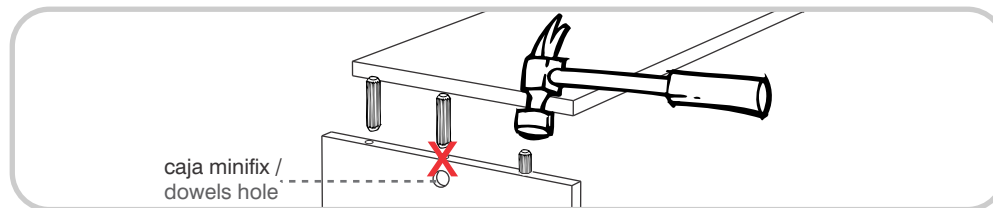

Es un pedazo de madera corto y grueso, de aproximadamente 3 a 10 cm de largo, que sirve para amarrar el mueble y darle resistencia.

It's a short and thick piece of wood, 1,18 to 3,9 inches approximately, which is used to tie the cabinet and give it resistance.

RECOMENDACIONES IMPORTANTES / KEY RECOMMENDATIONS

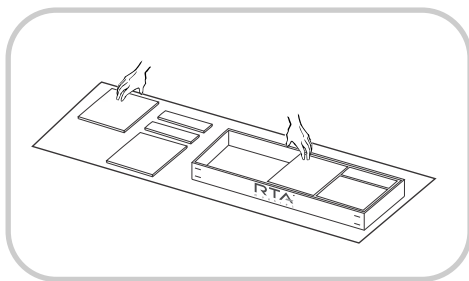

Se recomienda armar el mueble sobre la caja o una superficie lisa para no rayarlo. It is recommended to assemble the product on the box or on a flat surface to not scratch it.

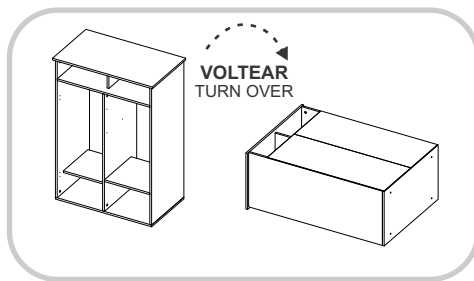

Voltear el mueble cuidadosamente para ensamblar los fondos. Carefully turn over the cabinet to assemble the back panels.

PESO MAX. SUGERIDO EN MUEBLE (Kg) / MAX SUGGESTED LOAD (Kg)

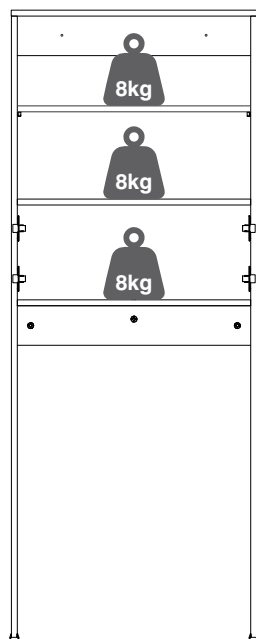

NOTA: La resistencia a las cargas puede variar dependiendo si es una carga distribuida o una carga puntual, las gráficas corresponden a cargas puntuales, NO exceder los pesos sugeridos / **NOTE:** The load capacity depends if it is a *point load* or if it is an *uniform distributed load*, do not exceed the suggested loads.

10

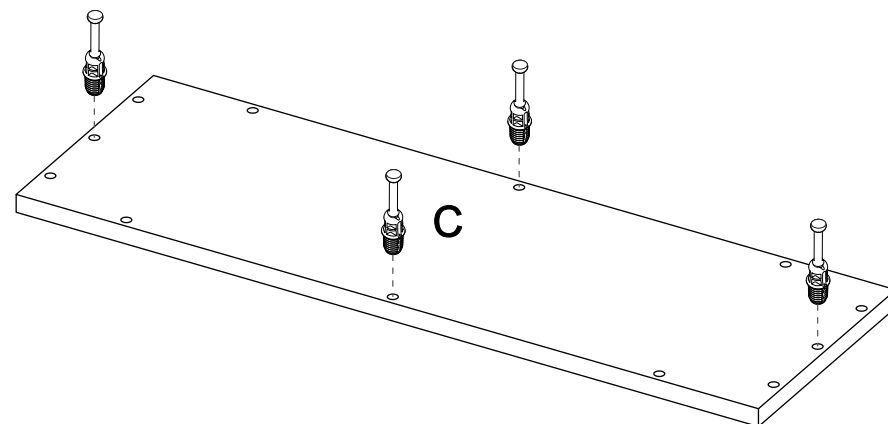

11

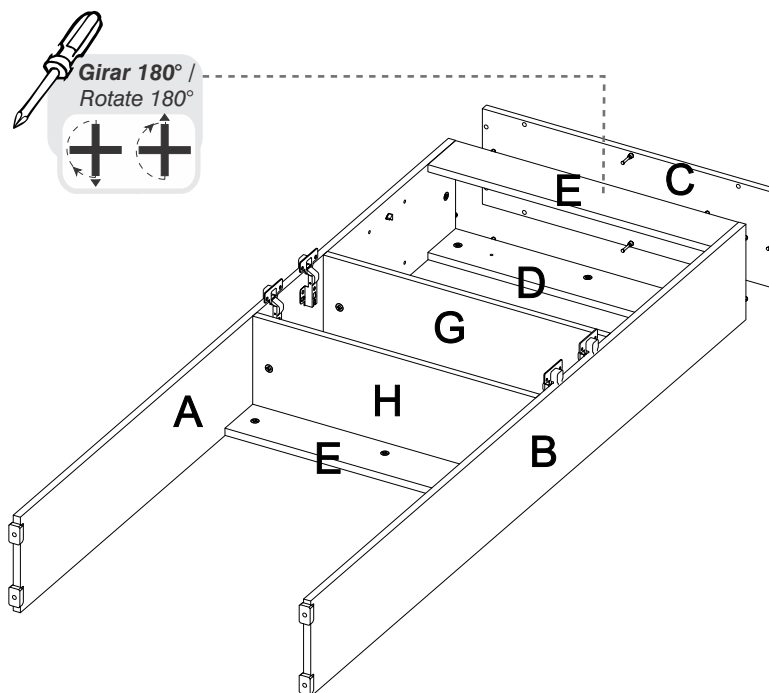

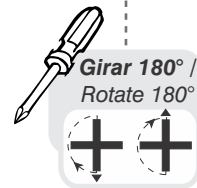
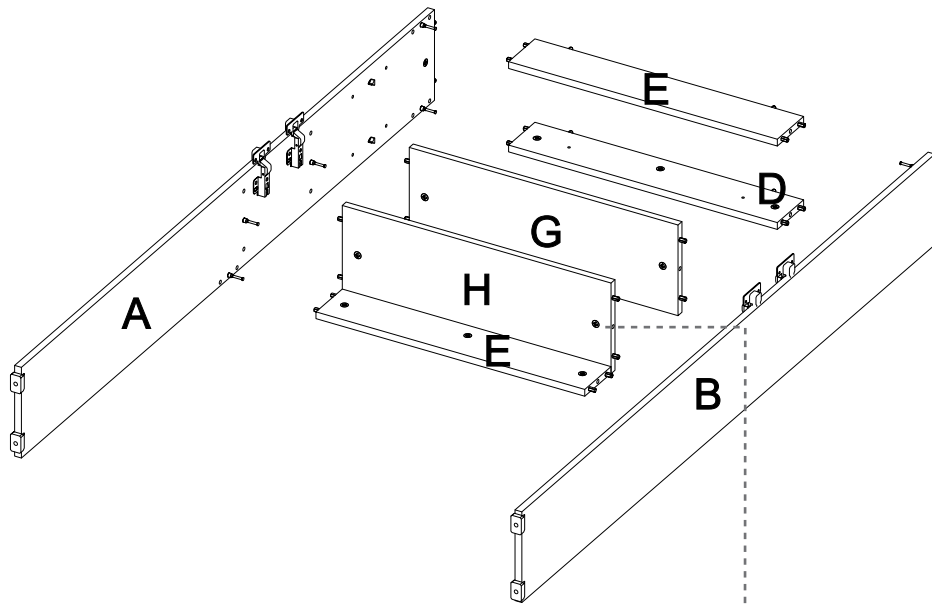

HERRAJES PARA ARMADO ASSEMBLY HARDWARE

x30



Tarugo/
Fluted Dowel Pin

x15



Perno minifix/
Spreading Bolt

x15



Minifix/
Minifix Cams

x17



Tapa Adhesiva
Minifix/
Cover Caps

x4

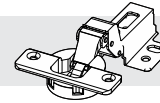

Bisagra Interior/
Inset Hinge

x2

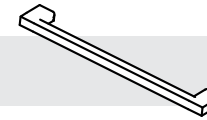

Manija/
Handle

x4



Tornillo Manija/
Handle Screw

x4

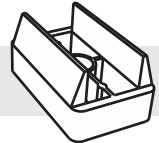

Deslizador en U/
Slider

x28



Tornillo Lámina/
Sheet Screw

x10



Puntillas/
Panel Pin

x5



Soporte entrepaño
Movil/ Mobile Shelf
Support

x2



Chazo Mariposa+
Tornillo ensamble 2 1/2"/
Plastic wall anchor +
2 1/2" Drywall Screw



TENER PRECAUCIÓN AL ABRIR LA BOLSA DE HERRAJES PARA NO EXTRAVIAR NINGUNO. COMPRUEBE QUE EL CONTENIDO DE LAS PIEZAS SEA EL CORRECTO. EN CASO QUE FALTE ALGUNA PIEZA O ESTE DEFECTUOSA DEVUELVA LAS PIEZAS AL ALMACÉN CON SU FACTURA PARA EFECTUAR EL CAMBIO DE LAS PIEZAS Y/O LOS HERRAJES LO MÁS PRONTO POSIBLE. / PLEASE BE CAUTIOUS WHEN OPENING THE HARDWARE BAG TO NOT LOSE ANY. CHECK THE CONTENTS OF THE PARTS ARE CORRECT. IF ANY PART IS MISSING OR IMPERFECT PLEASE RETURN THE PARTS TO THE STORE WITH THE PRODUCT INVOICE ATTACHED TO MAKE EFFECTIVE THE REPLACEMENT OF THE IMPERFECT PIECES OR HARDWARE AS SOON AS POSSIBLE.

PIEZAS DE ARMADO
ASSEMBLY PARTS

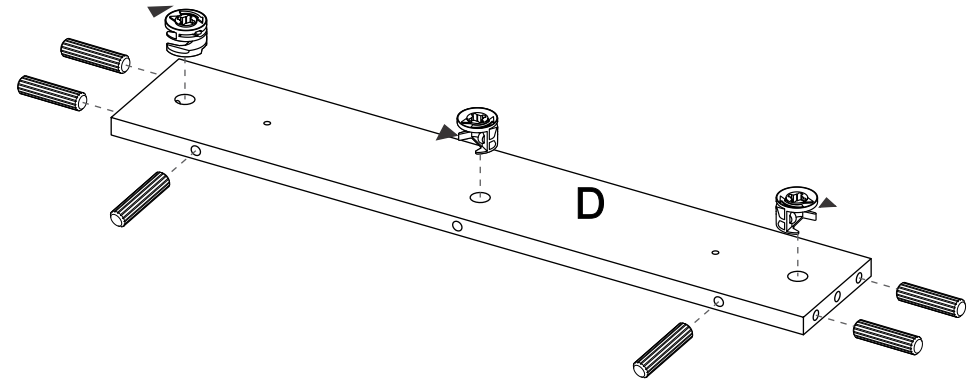
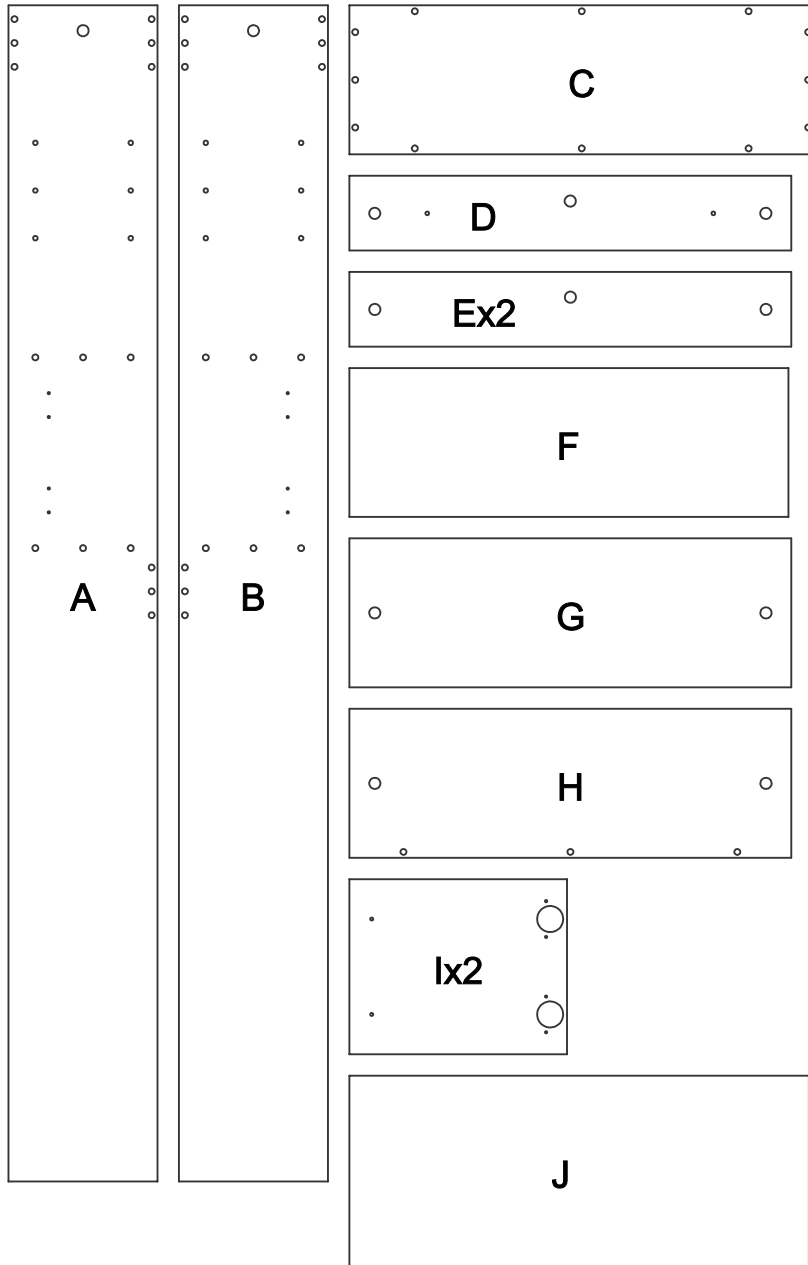

7

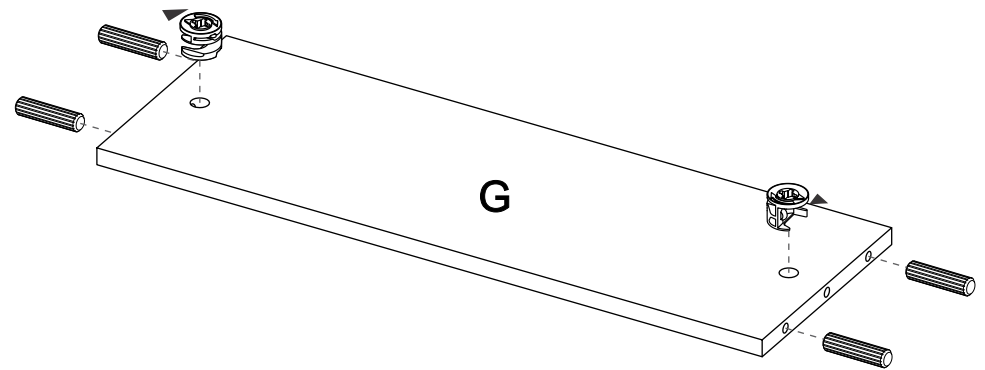

8



ANTES DE EMPEZAR A ARMAR EL MUEBLE LEA DETENIDAMENTE LAS INSTRUCCIONES. SE RECOMIENDA ARMAR EL MUEBLE SOBRE LA CAJA O SOBRE UNA SUPERFICIE LISA Y CUBIERTA, PARA NO RAYARLO / BEFORE STARTING TO ASSEMBLE THE CABINET, CAREFULLY READ THE INSTRUCTIONS. IT IS RECOMMENDED TO ASSEMBLE THE FURNITURE ON THE BOX OR ON A FLAT AND COVERED SURFACE IN ORDER TO NOT SCRATCH THE PRODUCT.

5

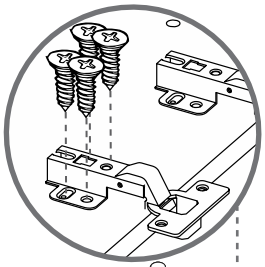
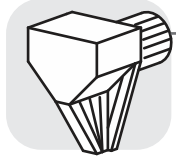

A

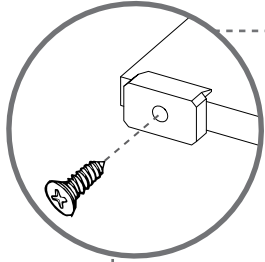

6

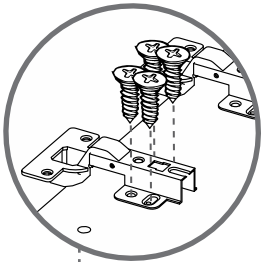

B

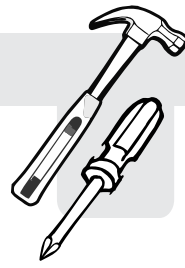

*(Herramientas NO incluidas) *Tools NOT Included

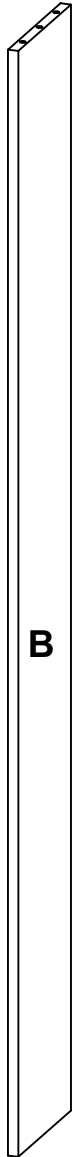
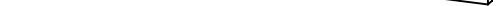
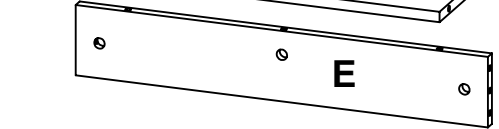
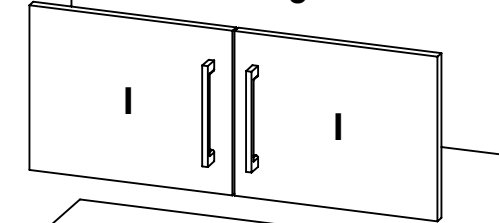
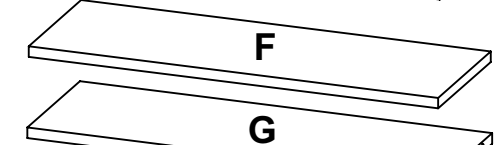
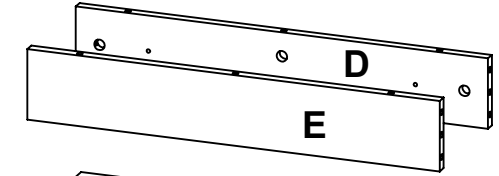
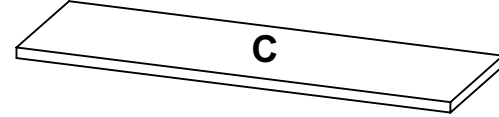

1

SE RECOMIENDA ARMAR EL MUEBLE ENTRE DOS PERSONAS /
IT IS RECOMMENDED TO ASSEMBLE THE PRODUCT BETWEEN TWO PEOPLE

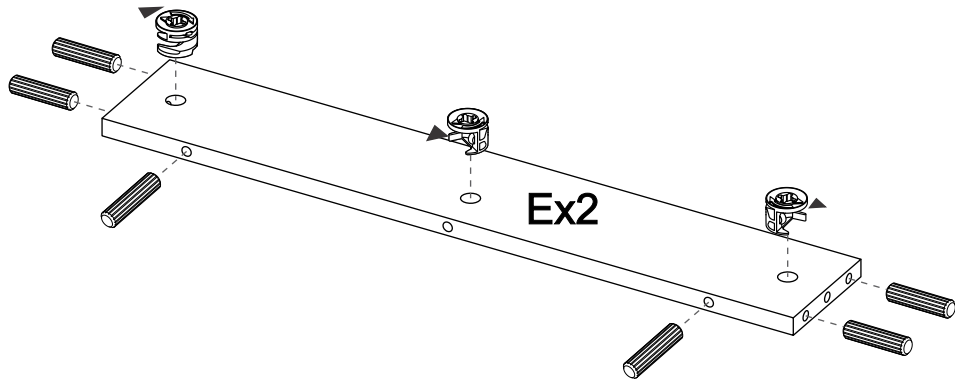
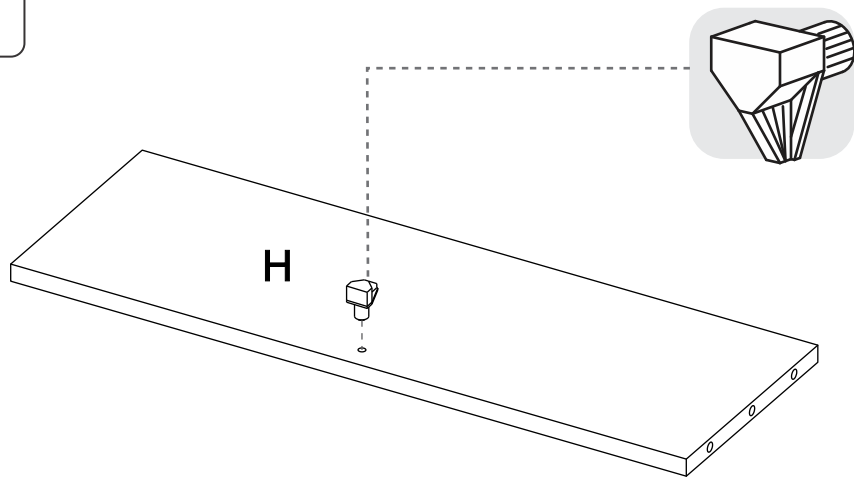
**2****3**

VOLTEAR
TURN OVER

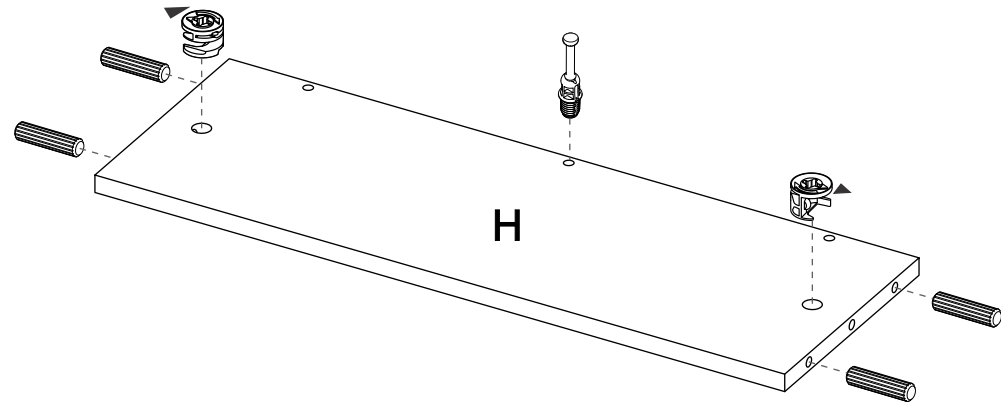
**4**