

51

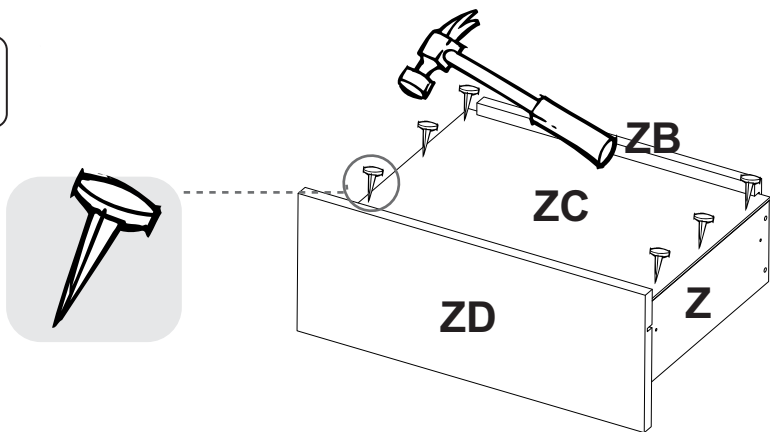

INTRODUZCA EL CAJON EN LA ESTRUCTURA /
PUT THE DRAWER INTO THE STRUCTURE



52

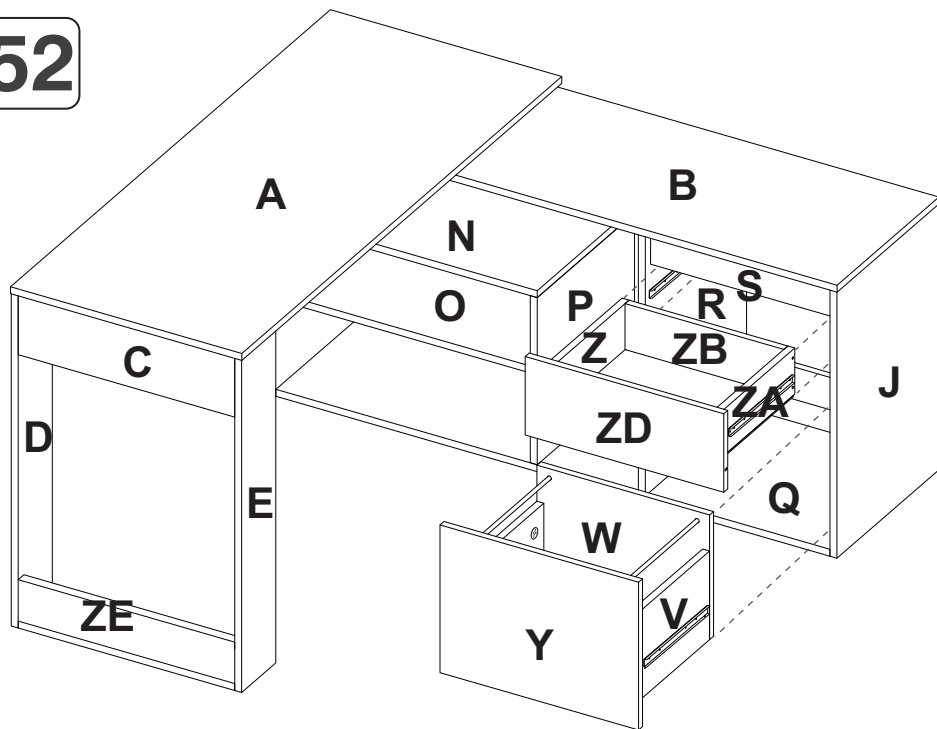

INSTRUCCIONES DE ENSAMBLE
ASSEMBLY INSTRUCTIONS

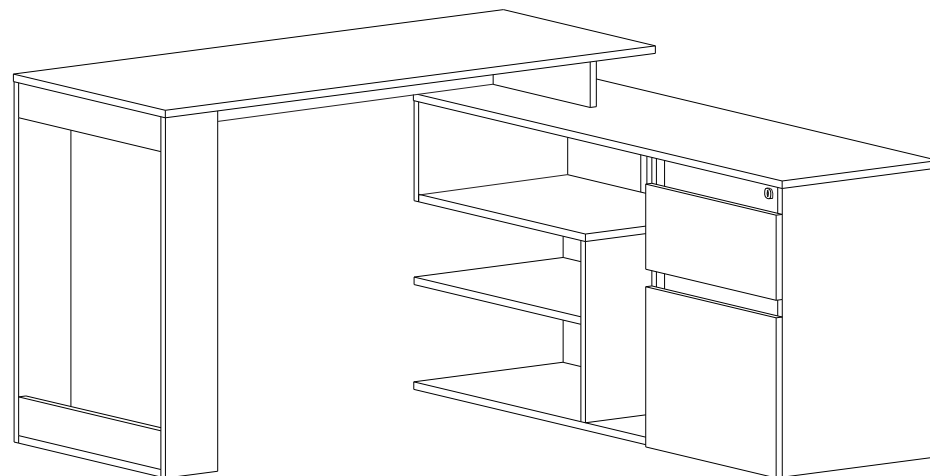

Alto/ Height: 73,5 cm
Ancho/ Width: 137,5 cm
Fondo/ Depth: 121,5 cm

LOTE No: _____

REF. ELW2333



Al terminar de armar desprenda los adhesivos (en caso de que queden residuos de pegamento, limpie la superficie con alcohol) / When you finish off adhesive build (in case of residues of glue, wipe it with alcohol)



Al finalizar el ajuste de los conectores, proceda a poner las tapas adhesivas / When you finish the adjustment of the connectors, proceed to put the cover tapes

By:  RTA DESIGN S.A.S.
TEL (572) 691 17 00
PBX (572) 695 91 81
CALI - COLOMBIA
www.rta.com.co

Escritorio **ALTEZA**
/ALTEZA Desk

**RECOMENDACIONES IMPORTANTES
KEY RECOMMENDATIONS**

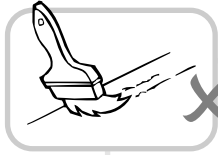

NO pinte el mueble/
Do not paint the
furniture.

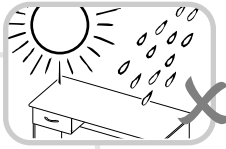

NO mojar o ubicar
a la intemperie/
Don't expose to rain
or direct sun.

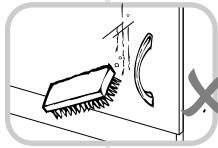

NO lavar las manijas o
tiraderas con jabones o
elementos abrasivos/
Don't wash handles
or dumps with soap or
abrasives.



NO sobrecargue el mueble.
no exceda el peso de 30 kilos
para gabinetes de cocina/
Do not overload the cabinet.
Weight not exceeding 66LB
for kitchen cabinets.

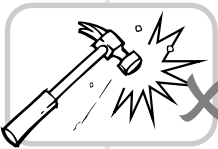

NO golpear ni martillar
el mueble (hágalo sólo
donde se indique)/
Don't hit or hammer
the furniture (just do it
where indicated).

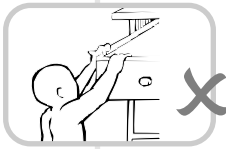

NO permita que los niños
manipulen el mueble, puede
voltearse y lastimarlos/
Do not allow children to
handle the cabinets
or drawers.



SIEMPRE levante el mueble
entre dos personas, NO lo
arrastre/ Do not drag the
furniture. Lift it between
two people.



Limpie con paño seco y
lustrador de muebles,
de esta forma alarga la
vida del mueble/Clean with
a dry cloth. Polishing wax for
furniture can be use.

**HERRAJES BÁSICOS PARA MUEBLES RTA
BASIC HARDWARE FOR RTA FURNITURE**

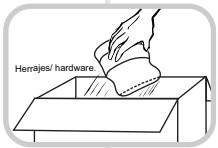

1. Abrir la caja del mueble
y buscar la bolsa con los
herrajes / Open the box and
look for the hardware bag.

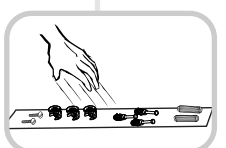

3. Separe los herrajes para
facilitar su identificación
durante el armado / Separate
hardware for easy identification
during assembly.

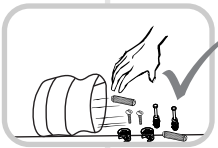

2. Abrir el paquete y
comprobar que el contenido
de las piezas es correcto /
Open the package and
verify that the content of the
pieces is correct.

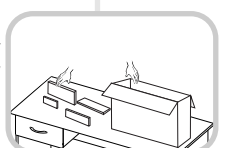

4. Arme el mueble en un lugar
limpio y en una superficie plana /
Assemble the furniture in a clean
place and on a flat surface.

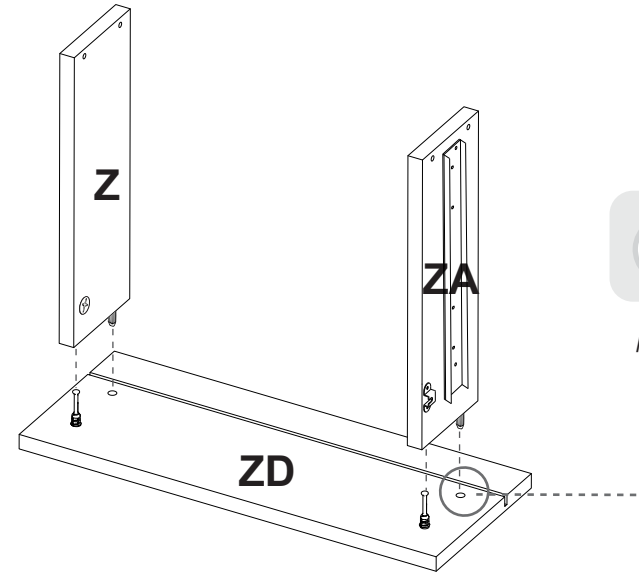

1 Gota x
perforación
/ 1 drop

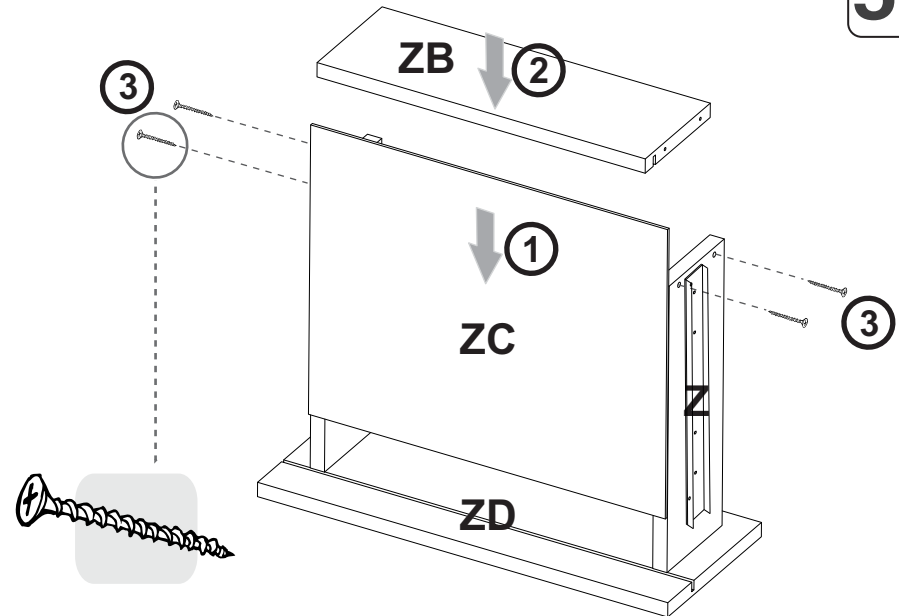

47

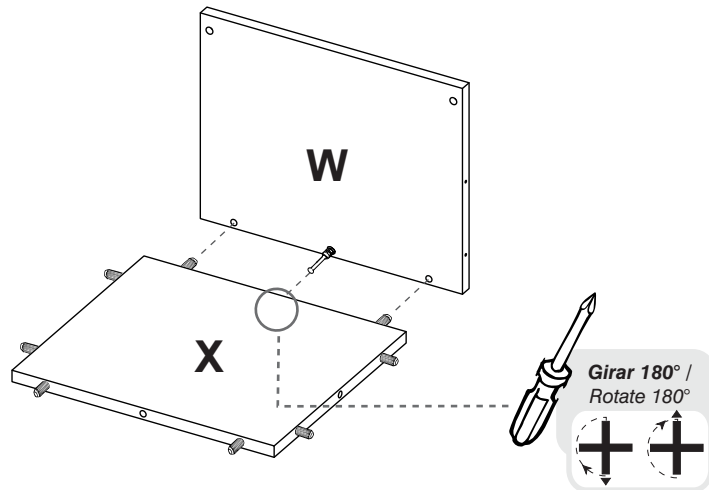

48

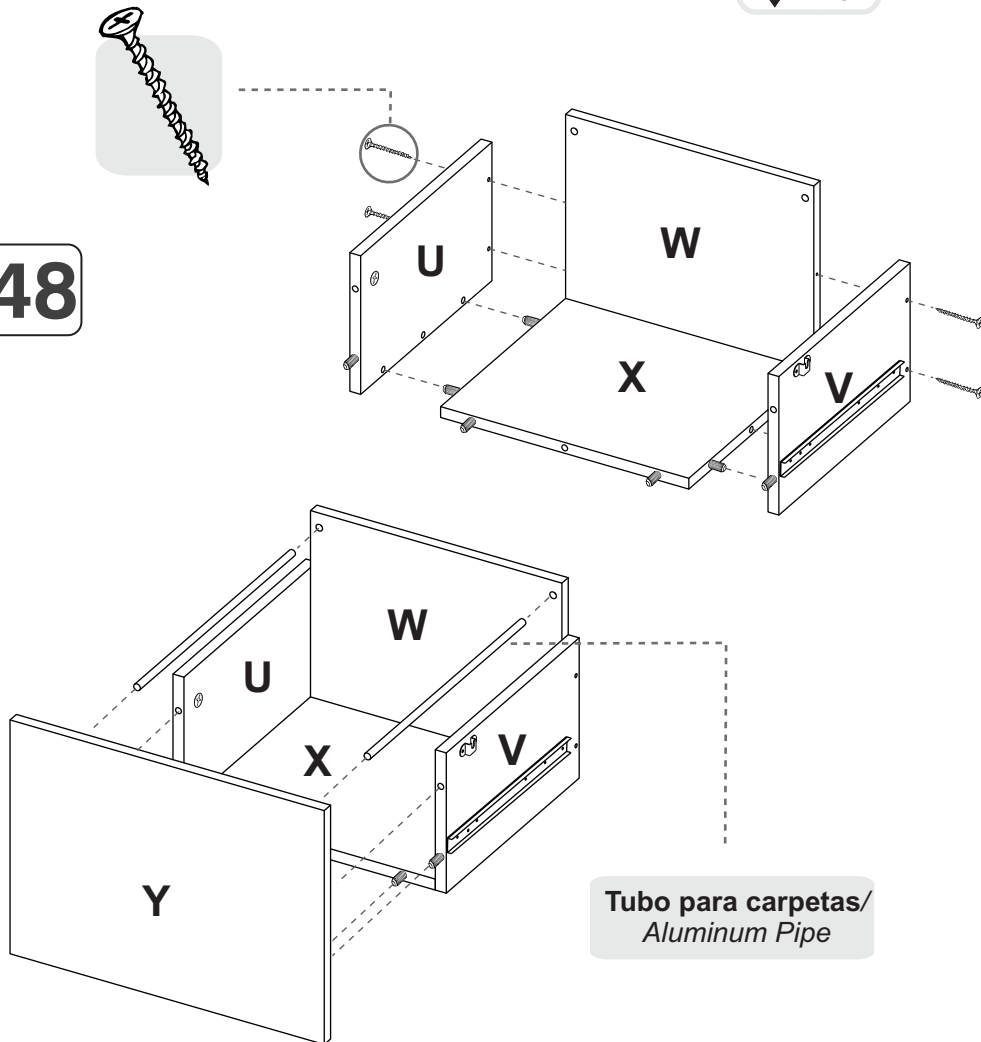

HERRAJES BÁSICOS PARA MUEBLES RTA

RTA FURNITURE HARDWARE (ready to assemble)

Siga las siguientes instrucciones:

1. Abrir la caja del mueble y buscar la bolsa con los herrajes.
2. Abrir el paquete de herrajes y comprobar que el contenido de las piezas es correcto.
3. Separe los herrajes para facilitar su identificación durante el armado.
4. Arme el mueble en un lugar limpio y en una superficie plana.

A continuación verá una breve explicación de cada herraje y su función principal.
Below you can see a explanation of each hardware and its main function.

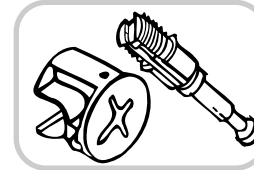

CONECTORES- PERNOS/CONNECTOR - SPREADING BOLTS

Es un herraje de unión, la cabeza esférica del perno se ubica en el centro de la caja embudida en forma de copa desde cualquier ángulo y luego se sujeta firmemente. Este permite un arme y desarme repetidamente y una unión firme que no se afloja. *It is a hardware union, spherical head of the pin is located in the center of the box embossed in the form of glass from any angle and then subject firmly. This allows for arming and disarming repeatedly and a strong union that is not loosened.*

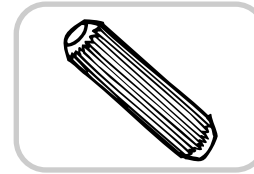

TARUGO DE MADERA/WOODEN PIN

Es un pedazo de madera corto y grueso, aprox. de 3cm a 10cm, que sirve para amarrar el mueble y darle resistencia. Tenga cuidado en aplicar una gota de pegamento en cada perforación de la cara en la que se pondrá el taquete. *It is a piece of wood short and thick, aprox. 5cm to 10cm, which serves to tie the cabinet and give it strength. Take care to apply a drop of glue drilling in each of the side you will be wooden pin.*

RECOMENDACIONES DE ARMADO

ASSEMBLY RECOMENDATIONS

El buen funcionamiento del mueble depende de su correcto armado.

Armed with a suitable furniture depends on its smooth functioning.

MINIFIX

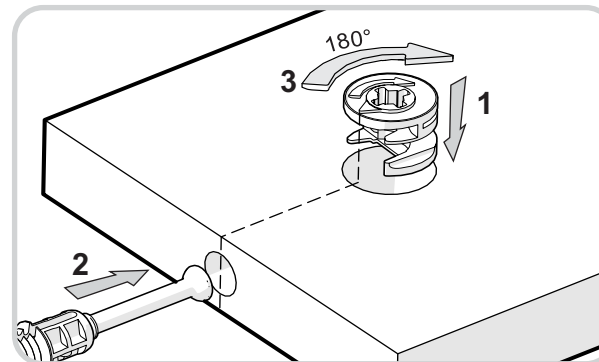

TAQUETE

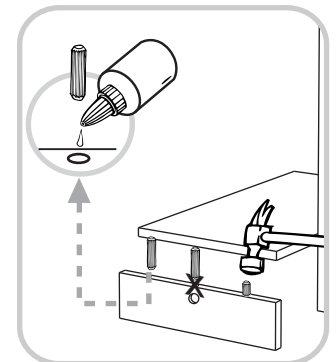

HERRAJES PARA ARMADO ASSEMBLY HARDWARE

x46



Minifix/
Minifix Cams

x46

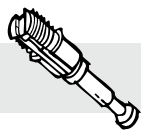

Perno minifix/
Dowels

x75

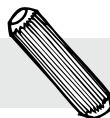

Tarugo/
Wooden pin

x46



Tapa Minifix/
Cover Caps

x2

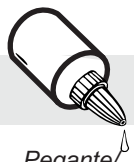

Pegante/
Glue

x20



Tornillo lámina
6 X 9/16"/
Sheet Metal Screw

x8



Tornillo de
ensamble 6 X 2"
/ Drywall screw

x8



Tornillo lámina 3/8"
/ Sheet Metal
Screw

x1

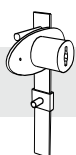

Cerradura Trampa
Cajón / Drawers and
cabinet lock

x2

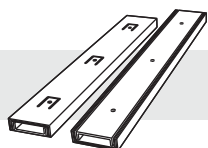

Riel Extensión total
/ Drawer slides

x10



Deslizador/
Plastic Glide

x35



Puntillas /
Panel Pin

x2

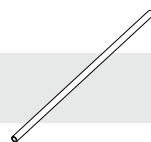

Tubo Para Carpetas
/ Aluminum Pipe



IMPORTANTE

TENER PRECAUCIÓN AL ABRIR LA BOLSA DE HERRAJES PARA NO EXTRAVIAR NINGUNO. COMPRUEBE QUE EL CONTENIDO DE LAS PIEZAS SEA EL CORRECTO. EN CASO QUE FALTE ALGUNA PIEZA O ESTE DEFECTUOSA NO DEVUELVA EL MUEBLE AL ALMACÉN, LE AGRADECEREMOS LLAMAR DE INMEDIATO A LA EMPRESA TEL: 57(4) 3252280 FAX: 57(4) 3140701 MEDELLÍN - COLOMBIA, TEL: 57(2) 6959181 CALI - COLOMBIA O ESCRIBIR AL CORREO ELECTRÓNICO comercial@rta.com.co INCLUYENDO EL NUMERO DE LA REFERENCIA Y EL NOMBRE DEL MUEBLEY ASÍ PODER RESOLVER SU PROBLEMA LO MAS PRONTO POSIBLE.

VOLTEAR EL MUEBLE CUIDADOSAMENTE PARA ENSAMBLAR
EL FONDO / CAREFULLY FLIP THE FURNITURE



45

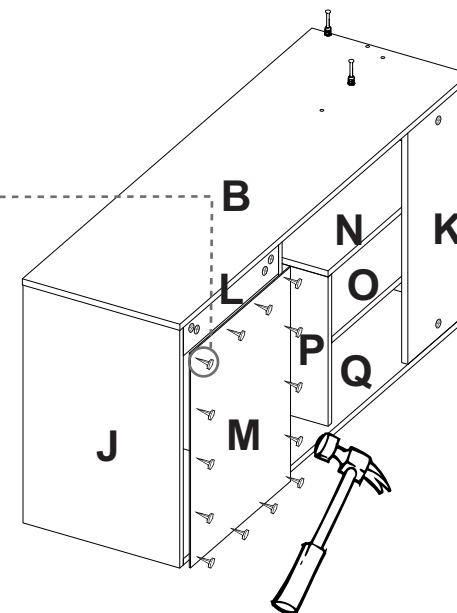

46

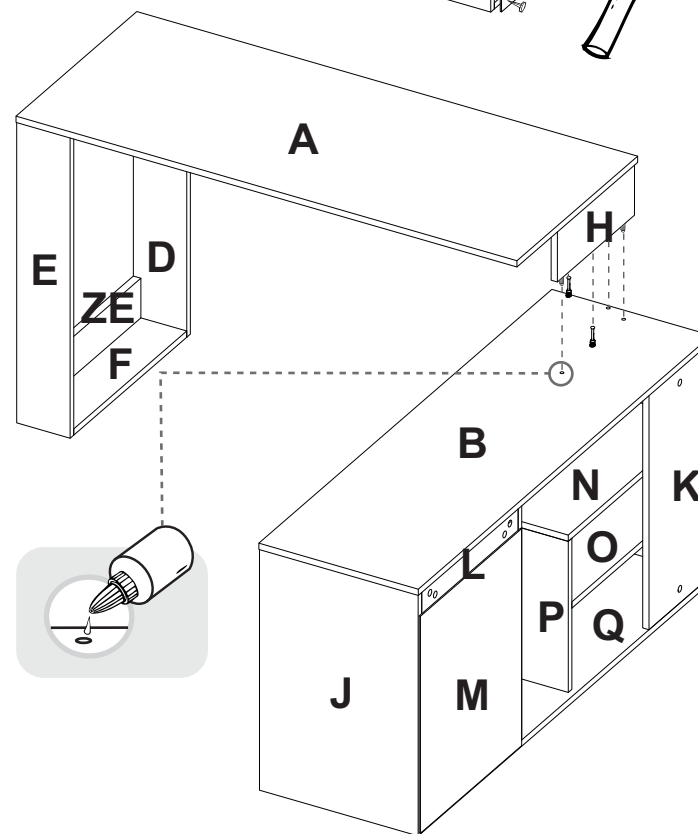

43

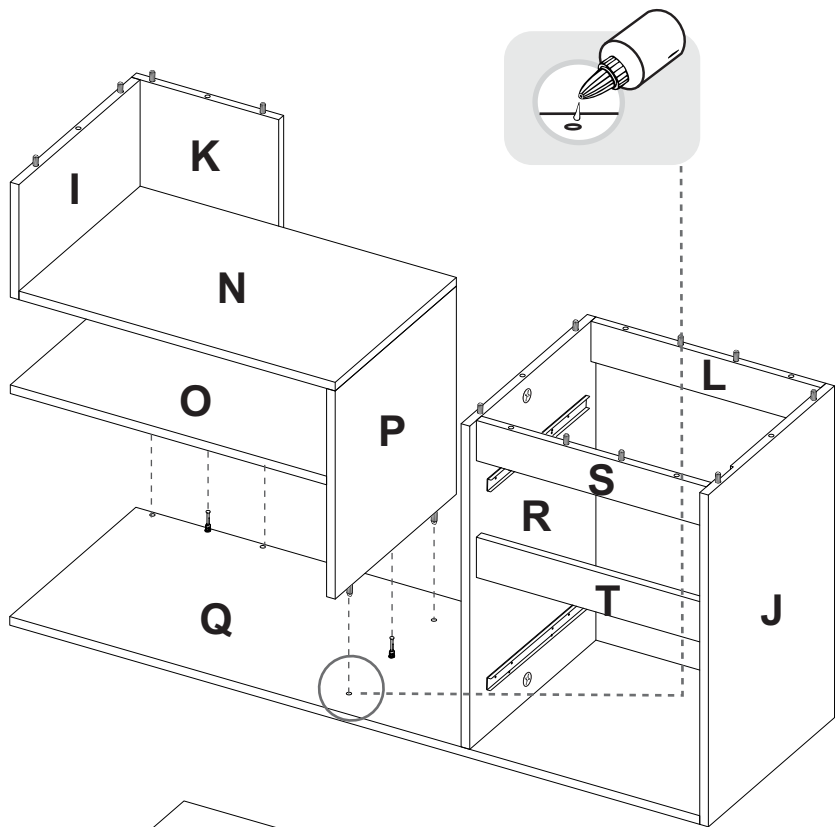

44

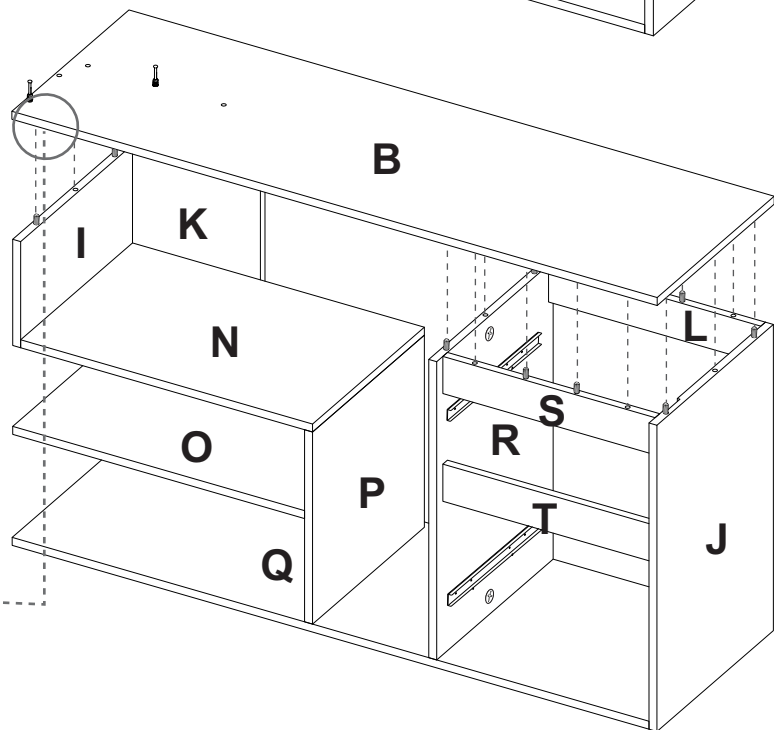

PIEZAS DE ARMADO
ASSEMBLY PARTS

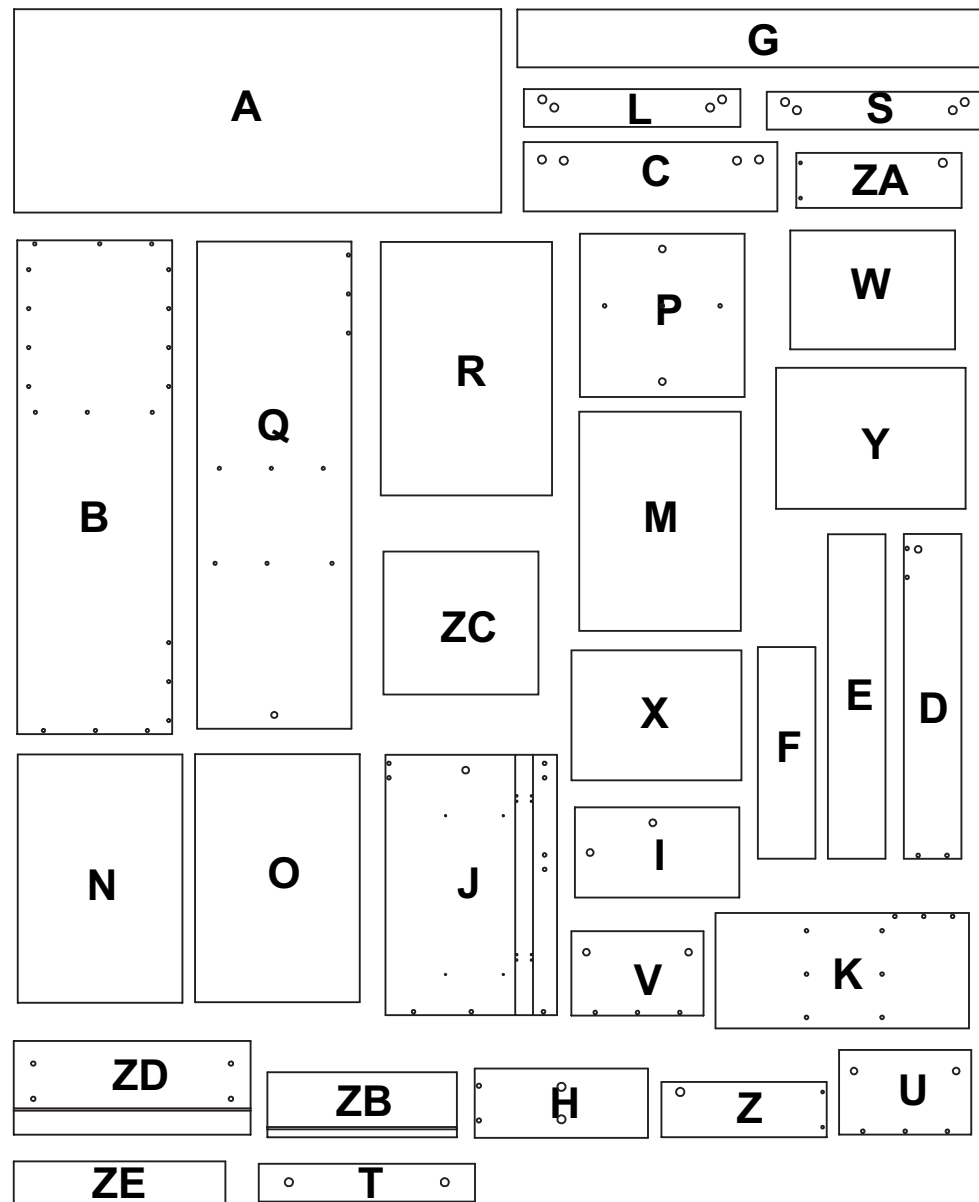

ANTES DE EMPEZAR A ARMAR EL MUEBLE LEA DETENIDAMENTE LAS INSTRUCCIONES. SE RECOMIENDA ARMAR EL MUEBLE SOBRE LA CAJA O SOBRE UNA SUPERFICIE LISA Y CUBIERTA, PARA NO RAYARLO / BEFORE STARTING TO ASSEMBLE THE FURNITURE, CAREFULLY READ THE INSTRUCTIONS. IT IS RECOMMENDED TO ASSEMBLE THE FURNITURE ON THE BOX OR ON A FLAT AND COVERED SURFACE IN ORDER TO NOT SCRATCH THE PRODUCT.

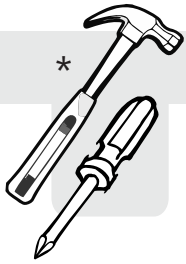

*

**Herramientas NO incluidas / Tools not included*

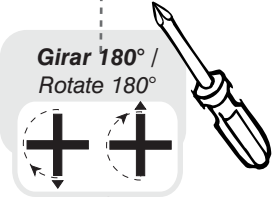
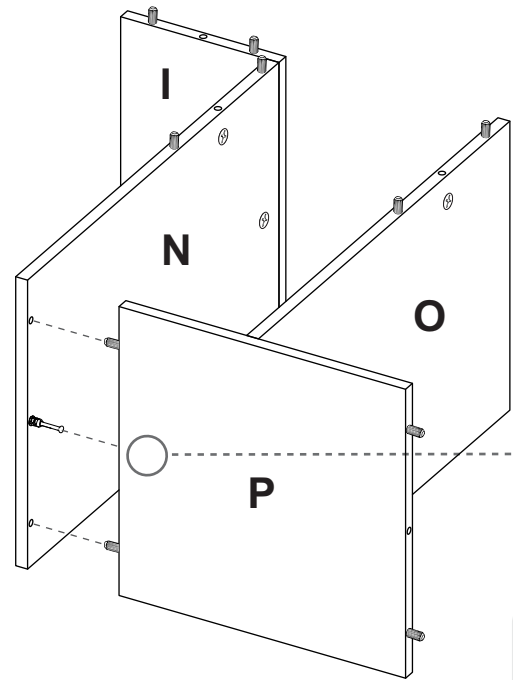
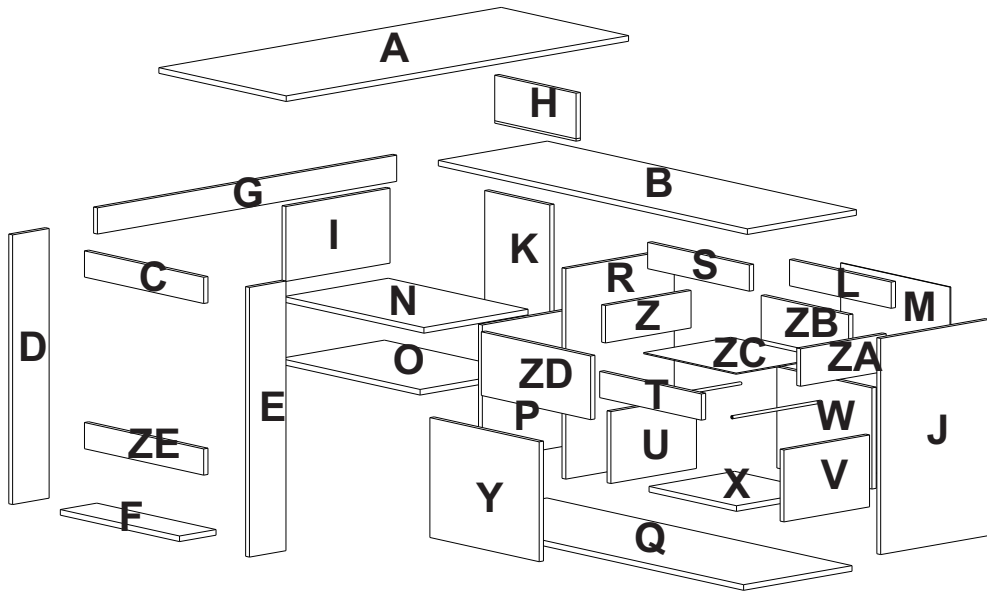

41

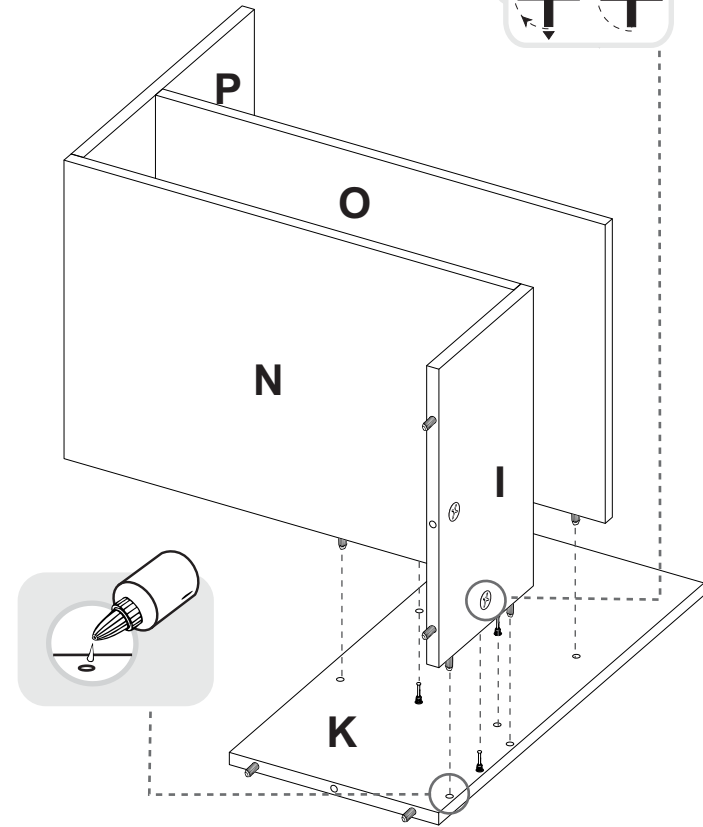

42

39

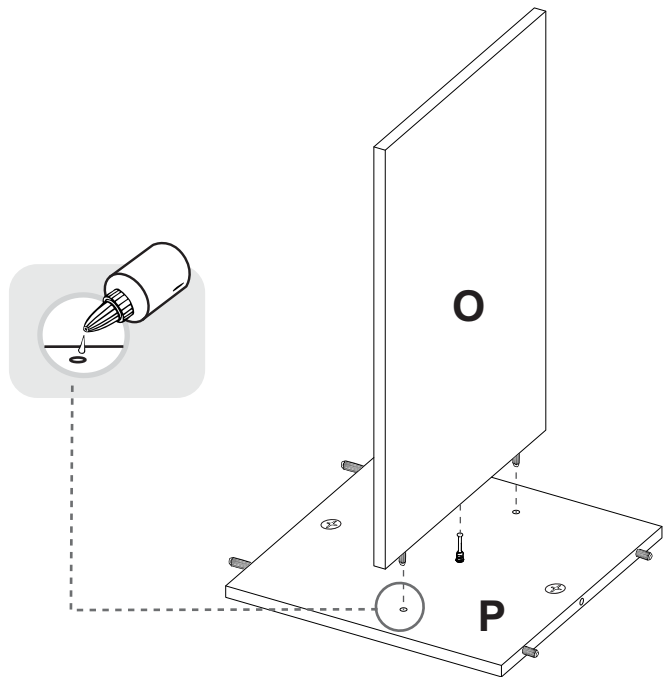

40

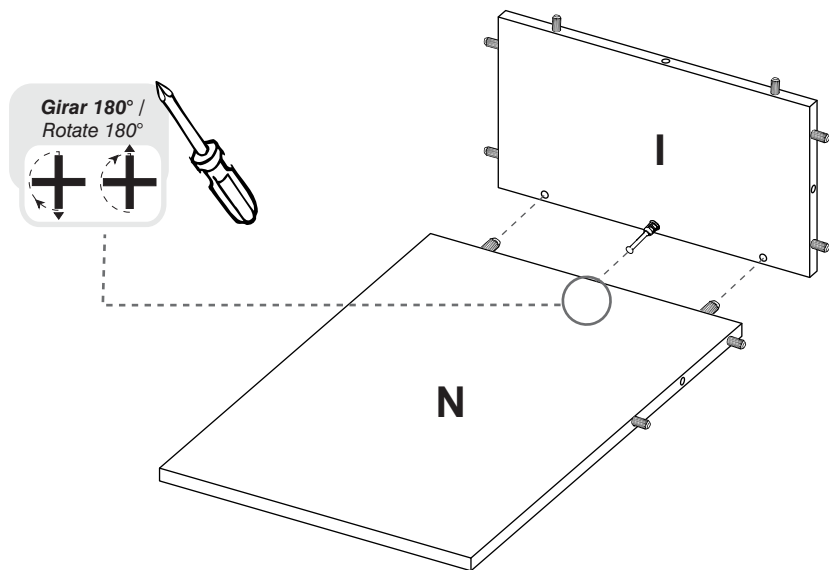

SE RECOMIENDA ARMAR EL MUEBLE ENTRE DOS PERSONAS /
IT IS RECOMMENDED TO ASSEMBLE THE PRODUCT BETWEEN TWO PEOPLE

1

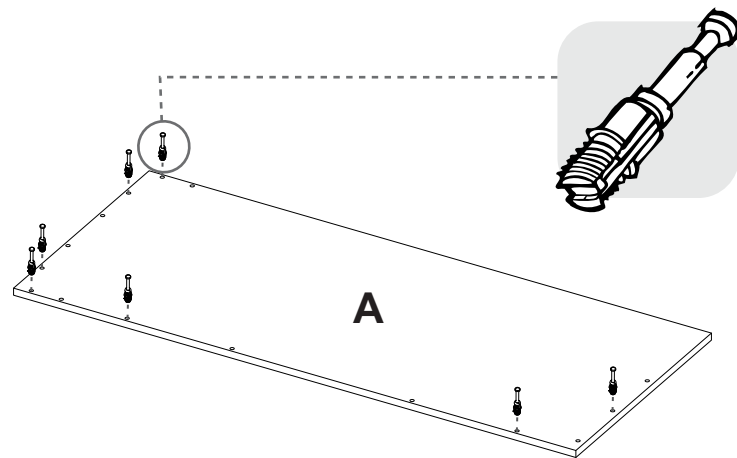

2

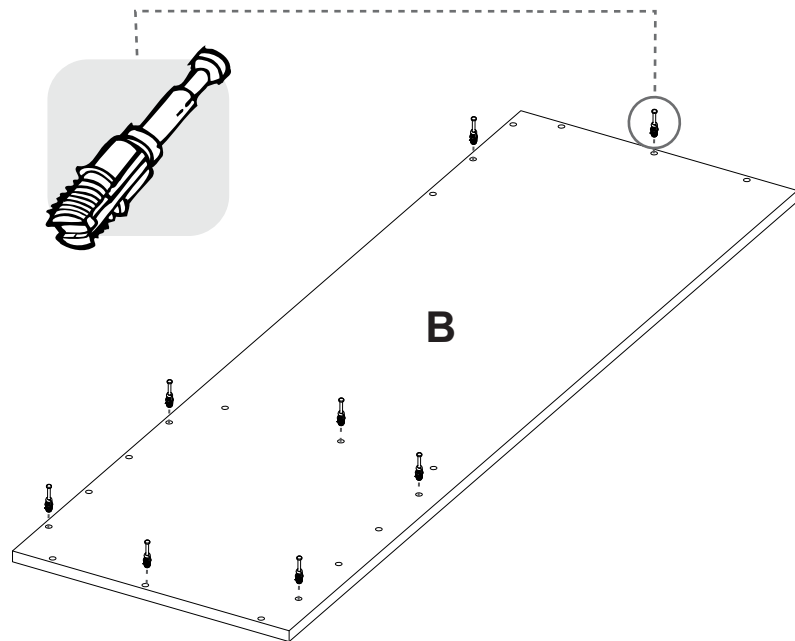

3

VOLTEAR
TURN OVER

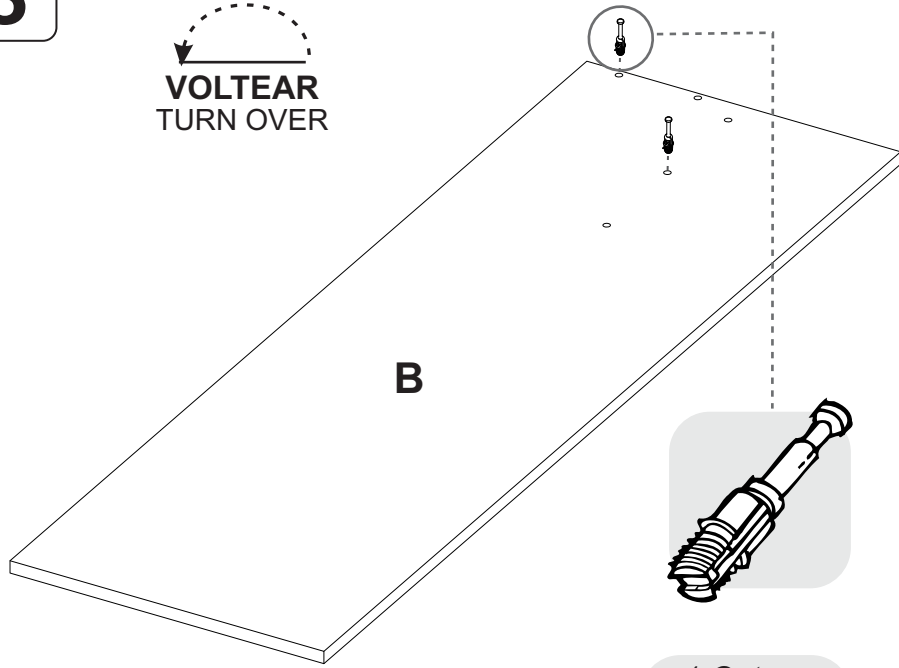

4

1 Gota x perforación
/ 1 drop

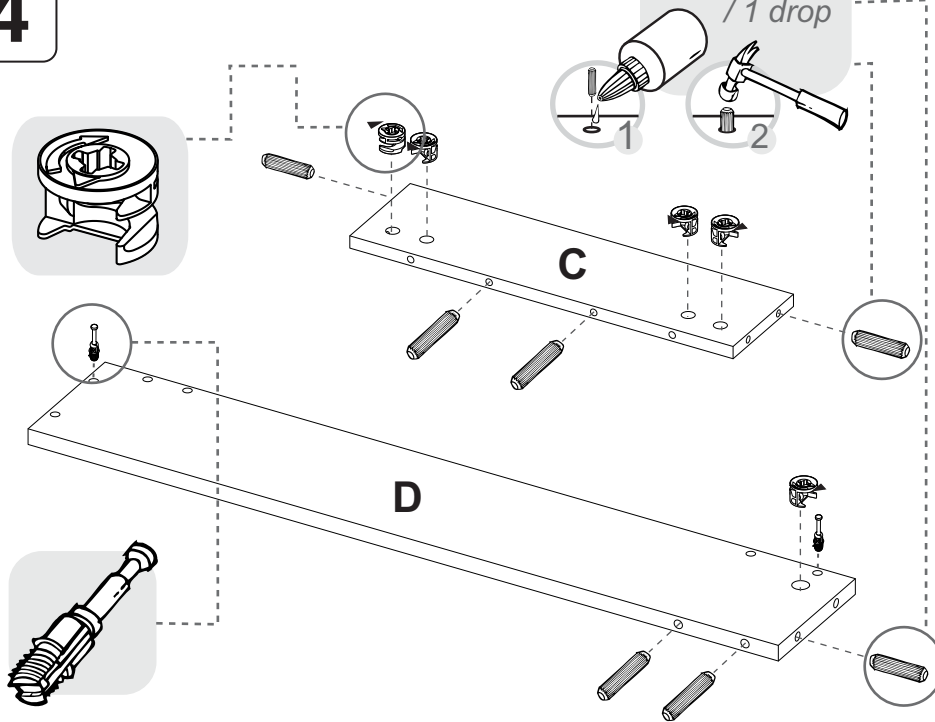

37

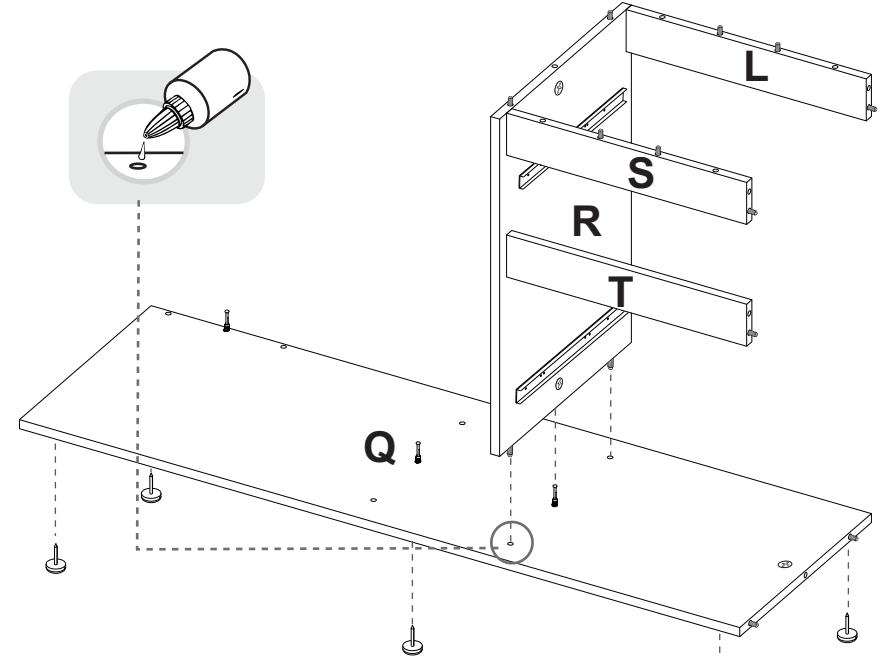

Girar 180° /
Rotate 180°



38

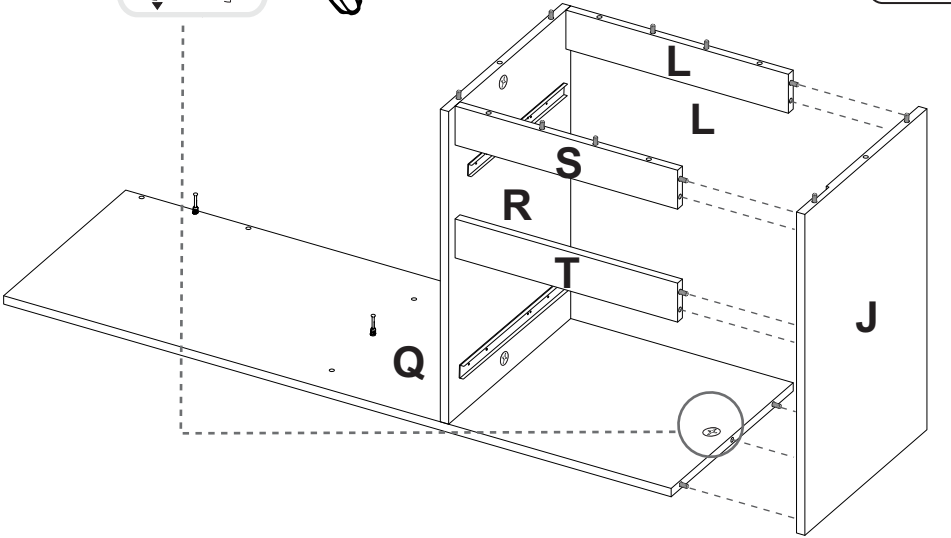

35

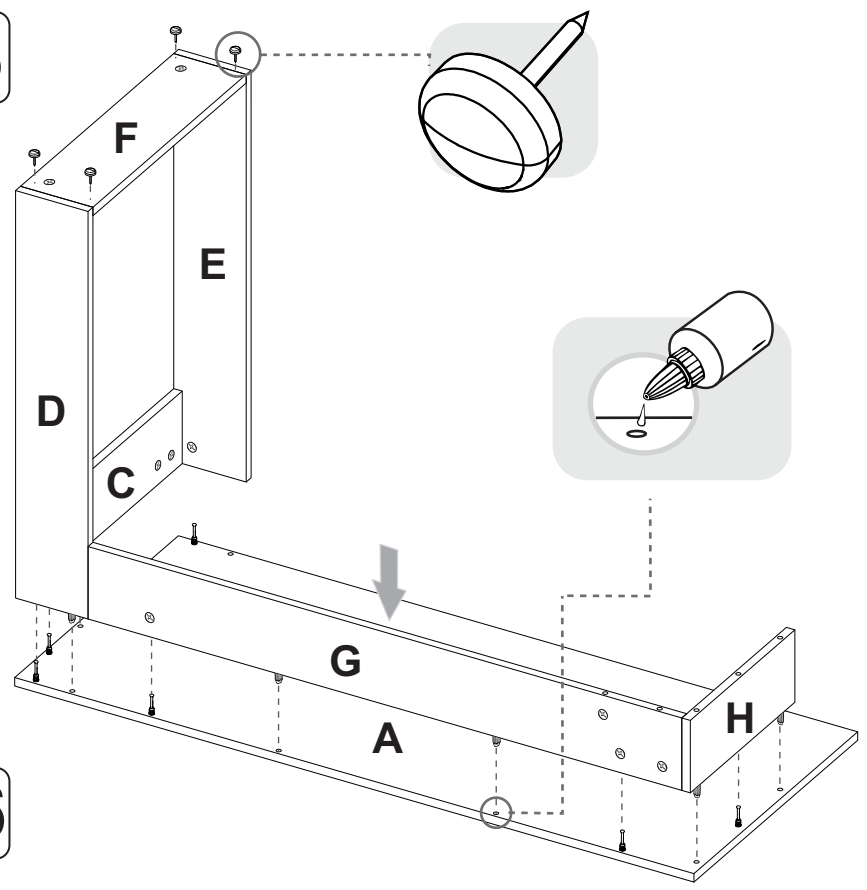

36

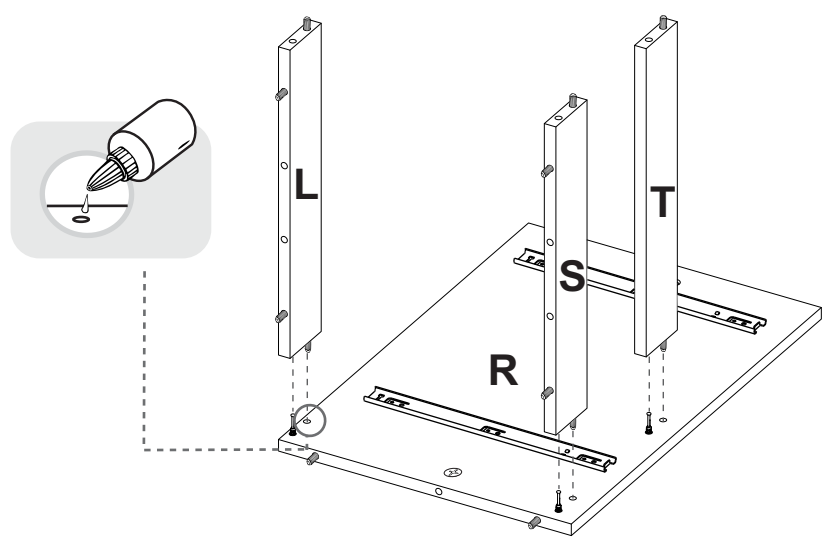

5

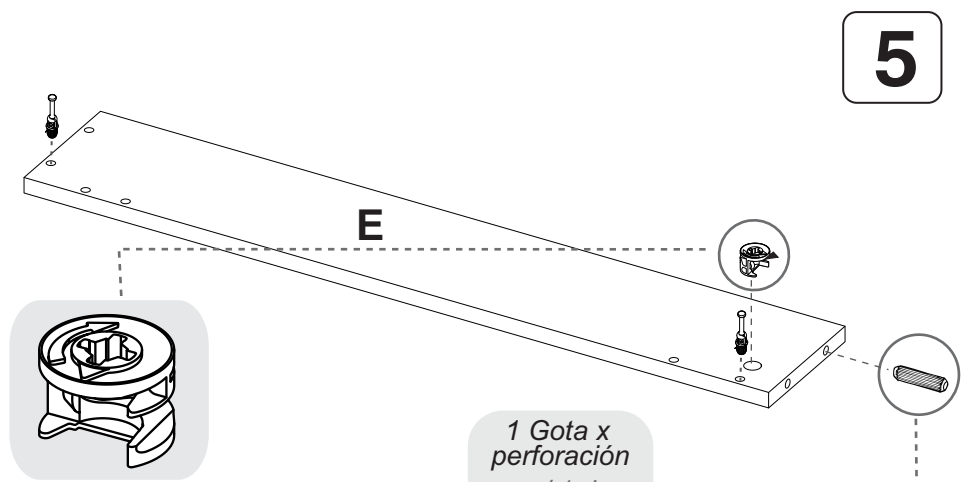

1 Gota x perforación / 1 drop

6

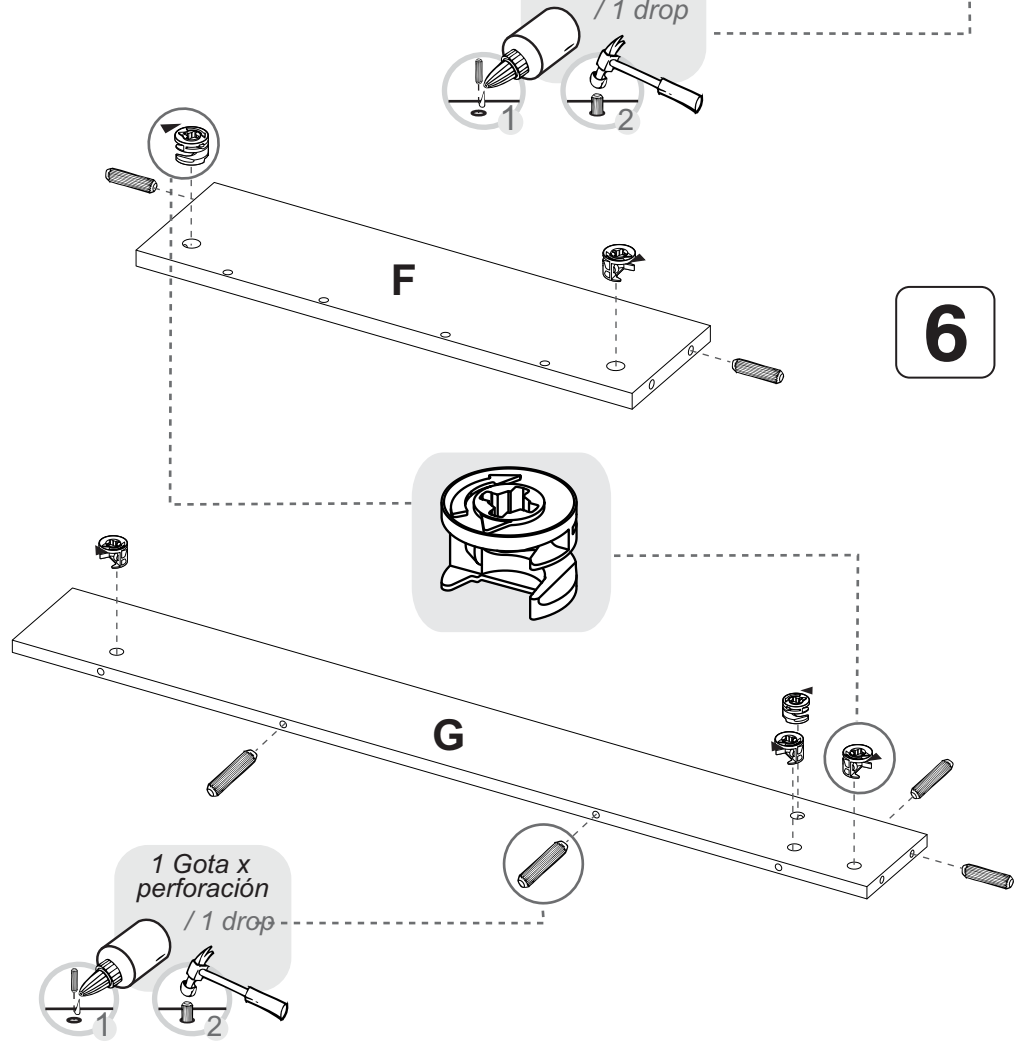

1 Gota x perforación / 1 drop

7

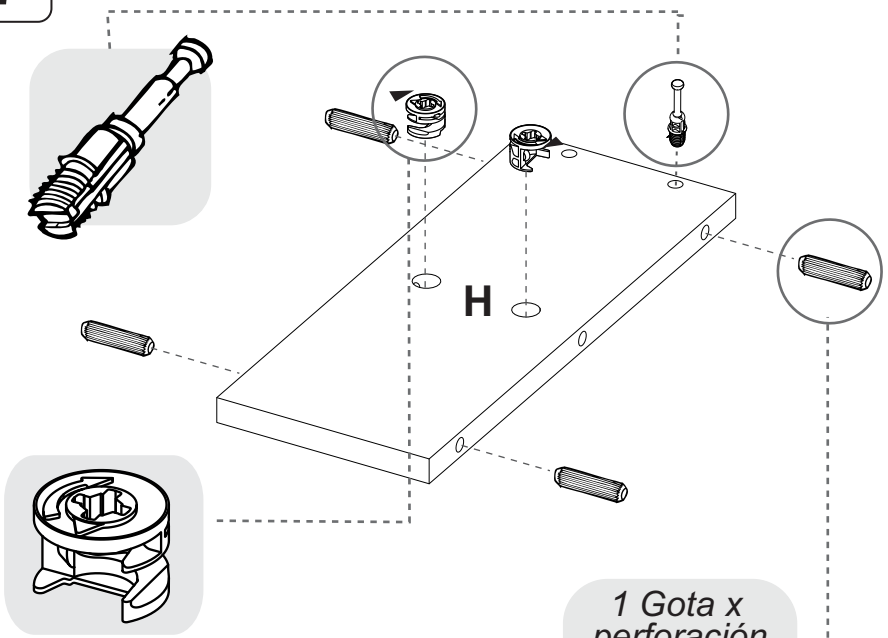

8

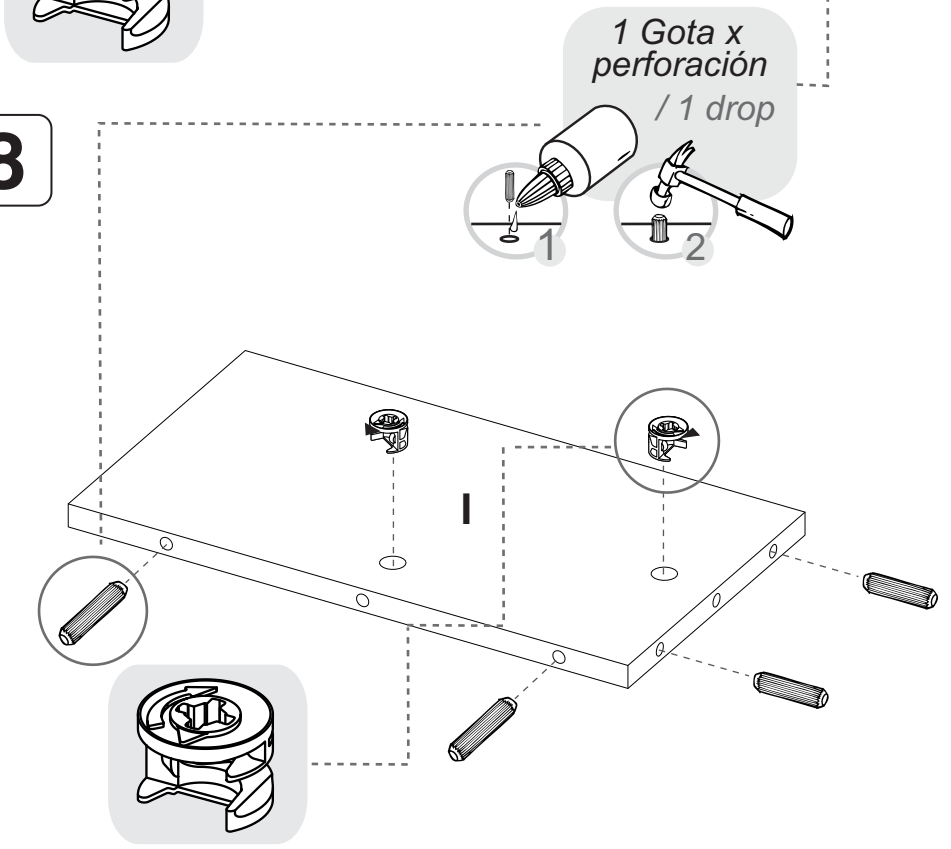

33

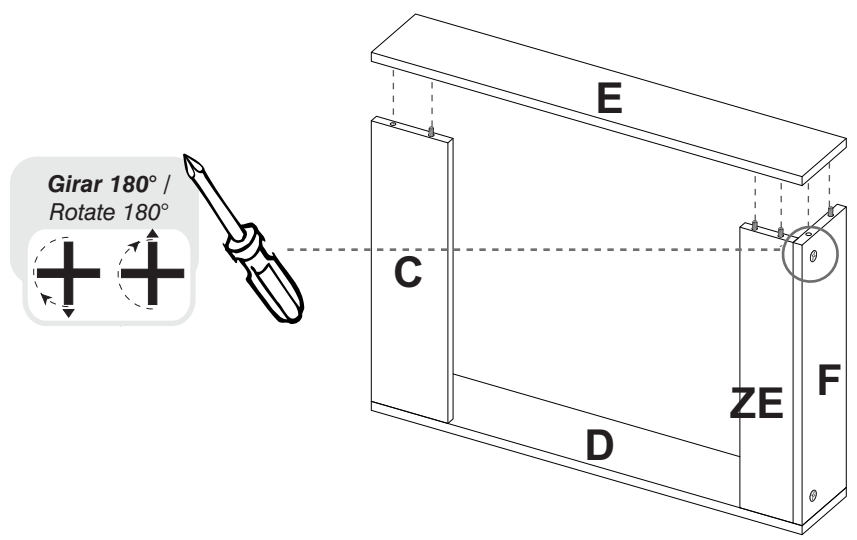

34

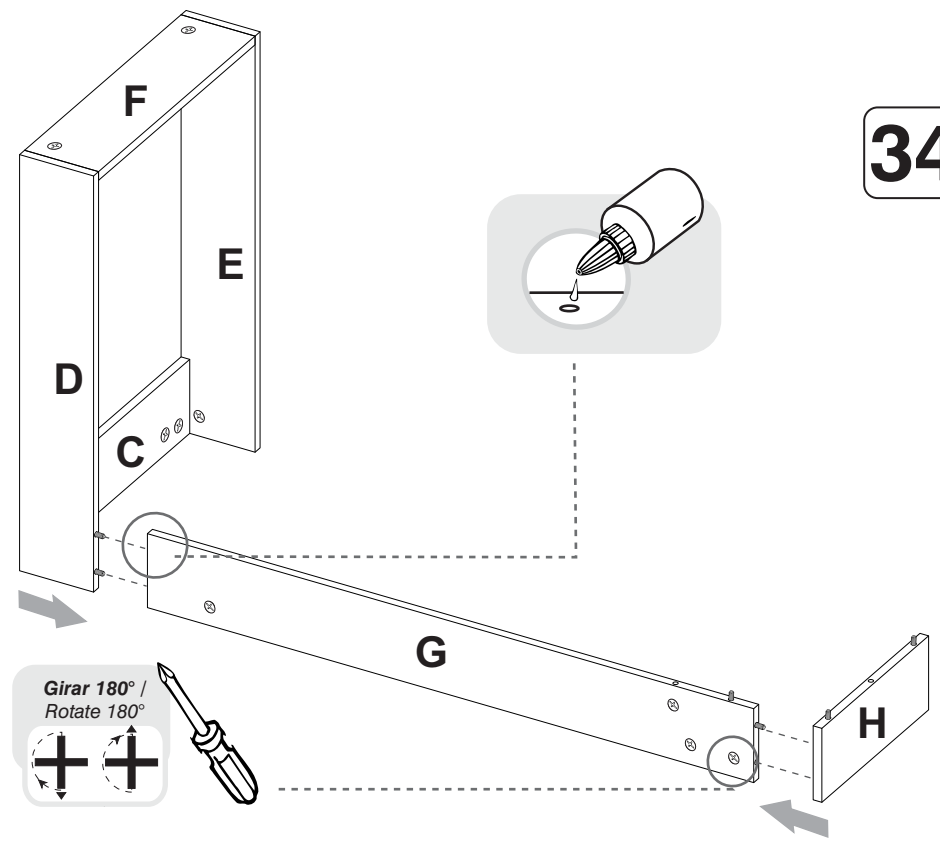

31

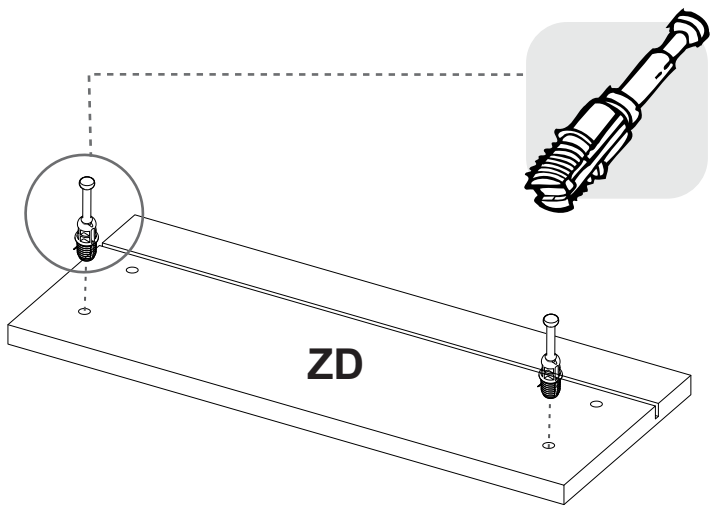

32

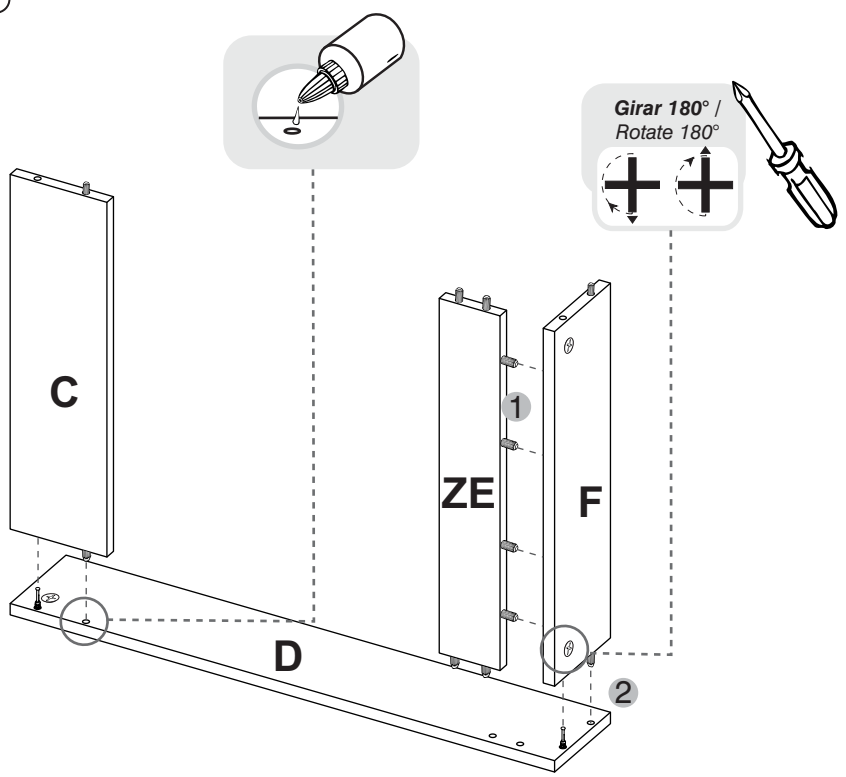

9

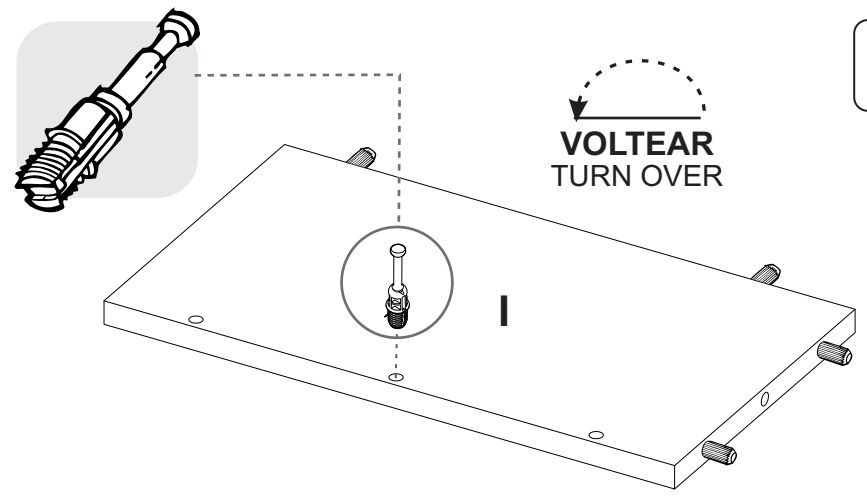

10

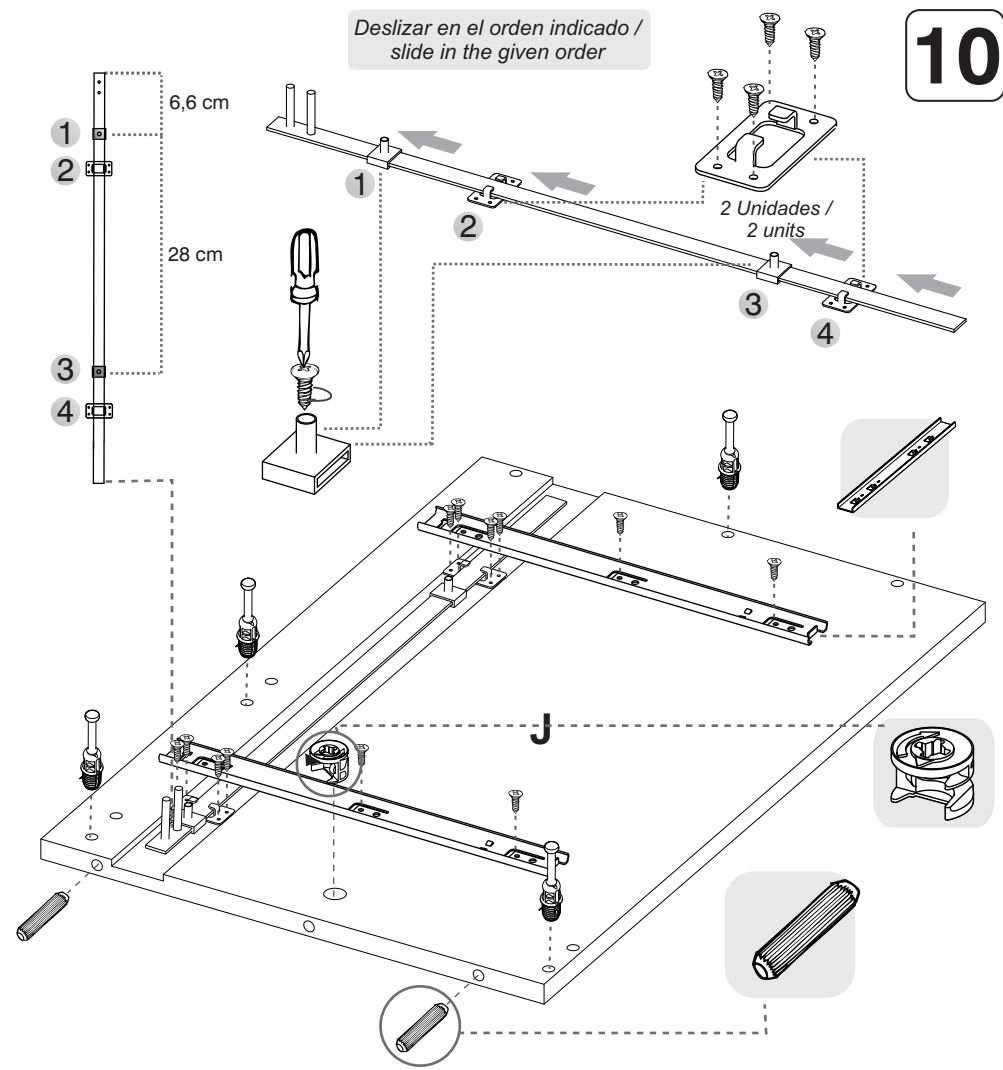

11

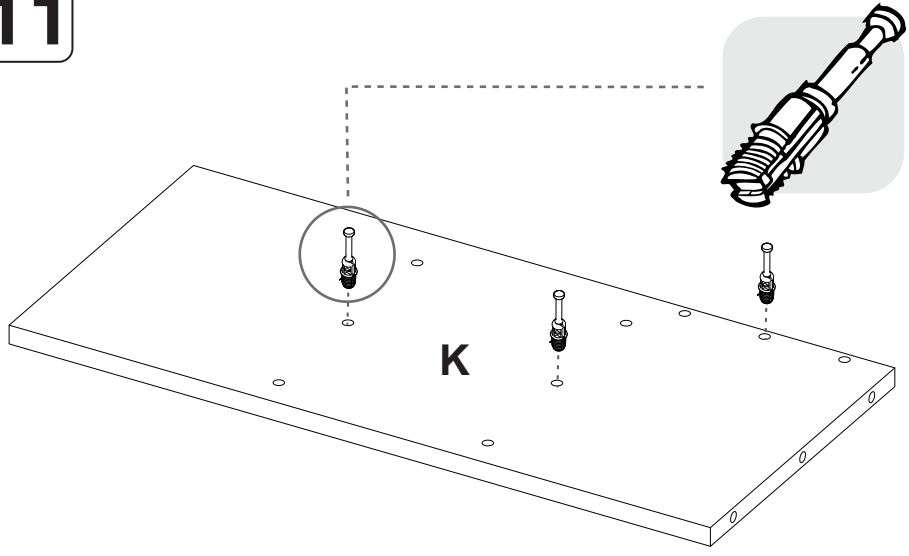

1 Gota x perforación
/ 1 drop

12

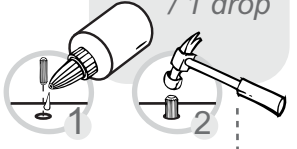

VOLTEAR
TURN OVER

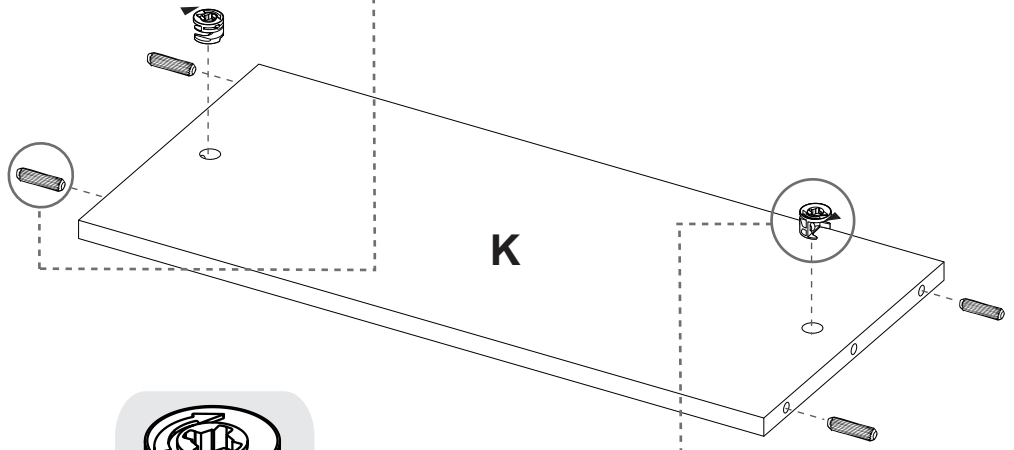

29



INSTALACIÓN DEL RIEL
/ DRAWER SLIDES
INSTALATION:

Revisar que el tope
metálico del riel quede en
la PARTE DELANTERA/
The metallic stop should be
placed on the front.

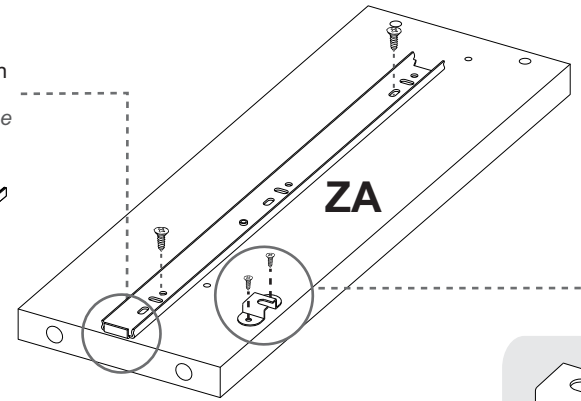
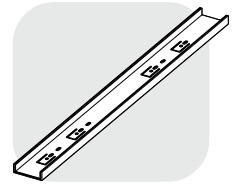

1 Gota x perforación
/ 1 drop

30

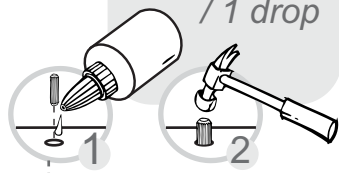

VOLTEAR
TURN OVER

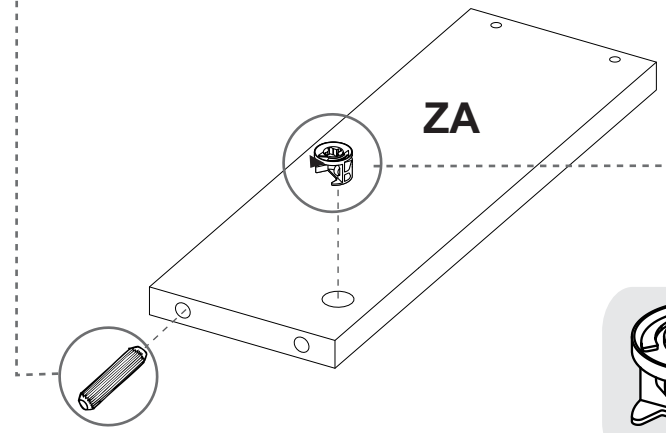

27



Revisar que el **tope metálico** del riel quede en la **PARTE DELANTERA** /
The **metallic stop** should be placed on the front.

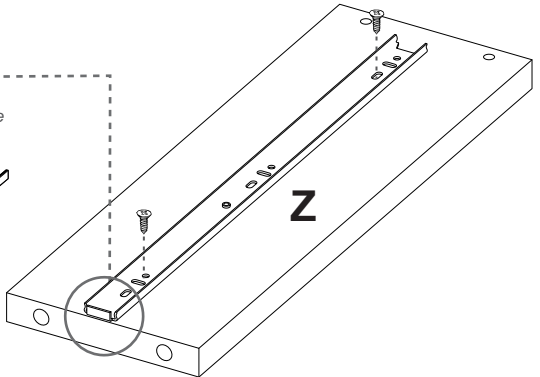
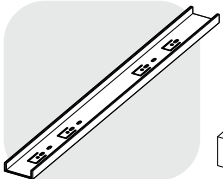

28

1 Gota x perforación / 1 drop

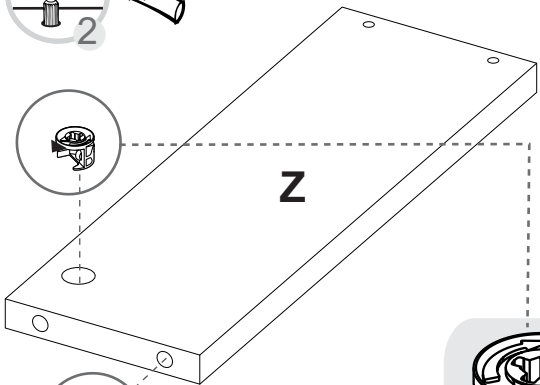
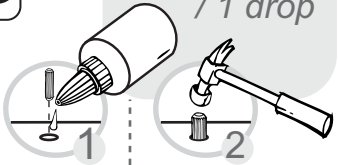

VOLTEAR
TURN OVER



13

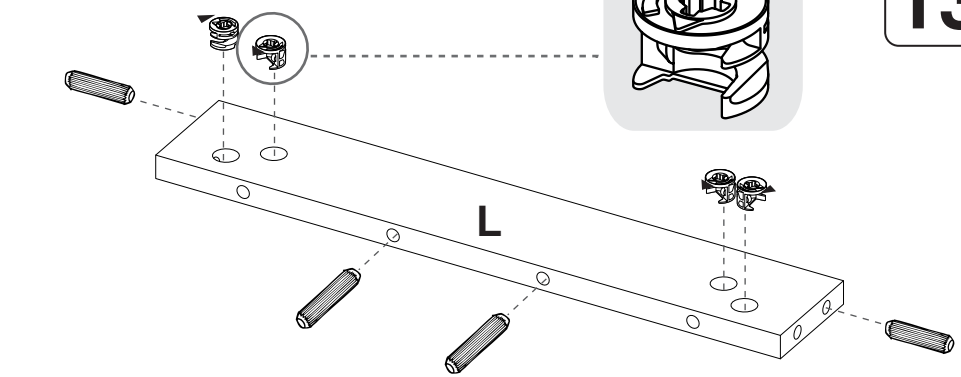

14

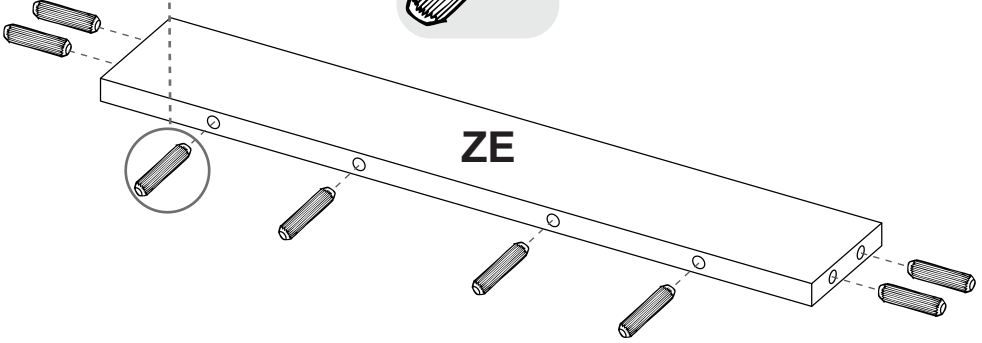
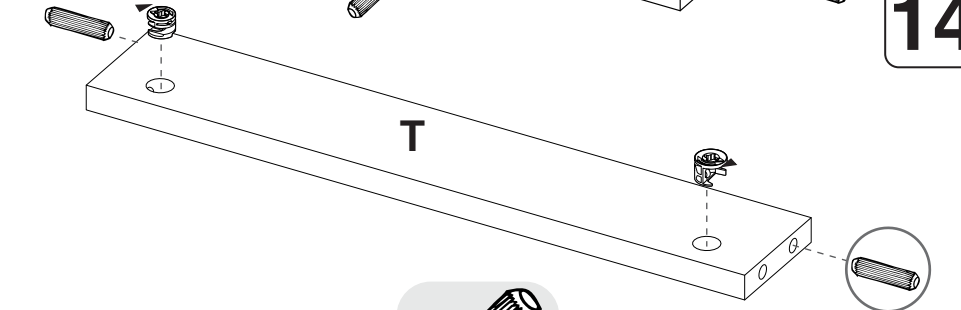
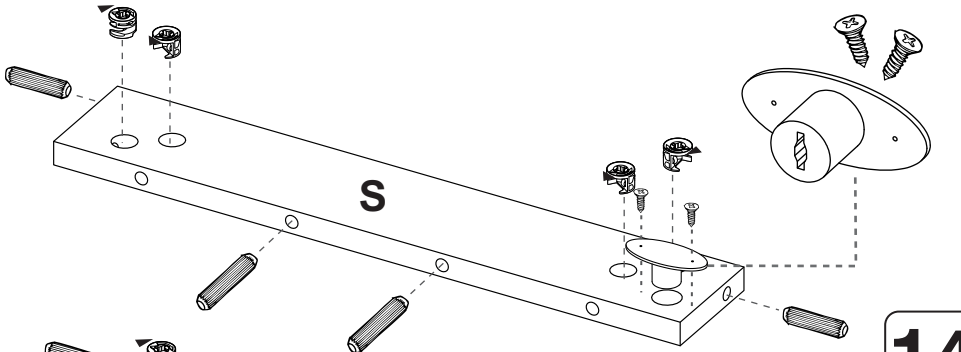

15

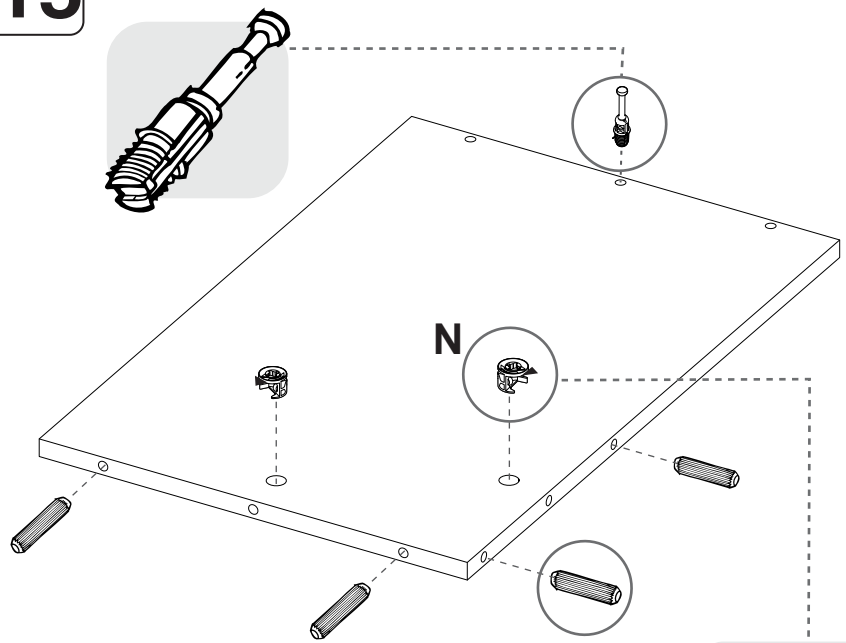

16

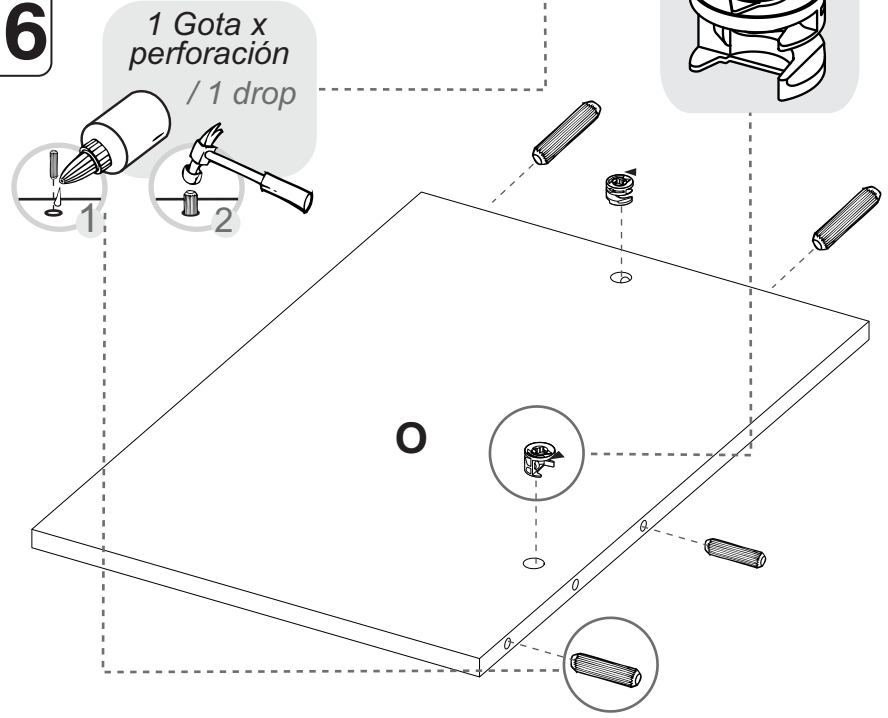

25

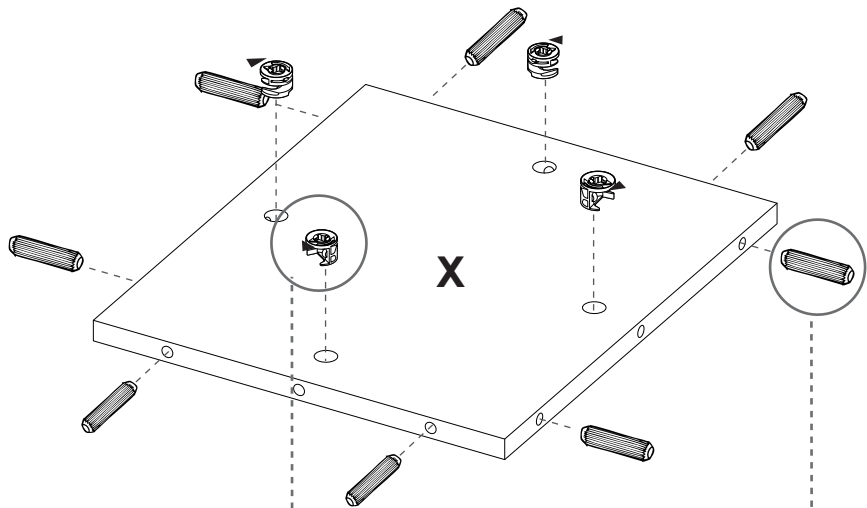

26

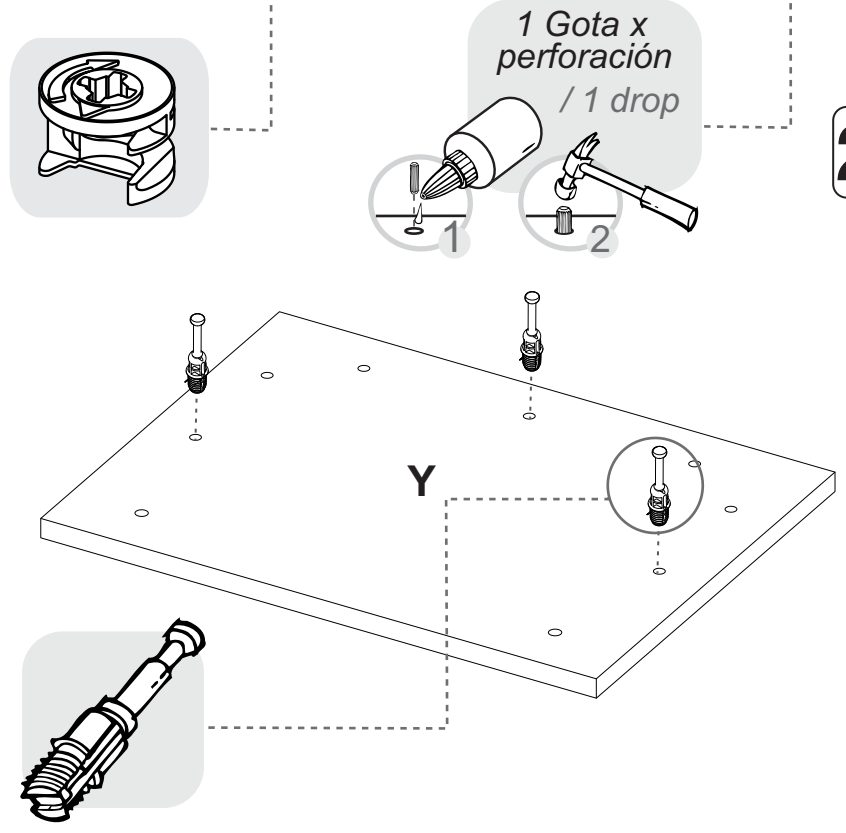

23

VOLTEAR
TURN OVER

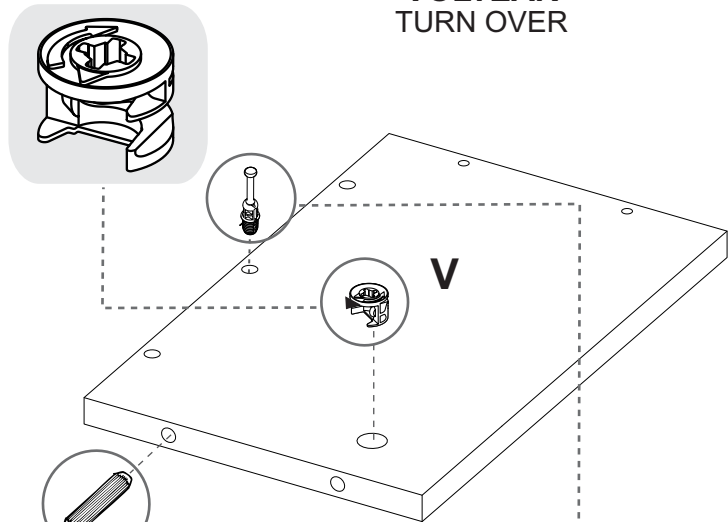

24

1 Gota x perforación
/ 1 drop

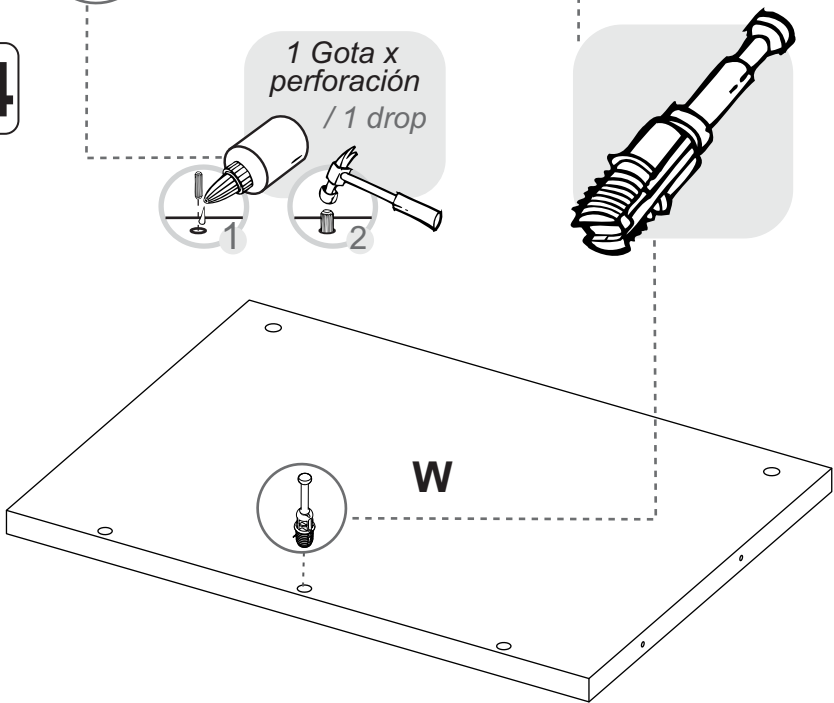

17

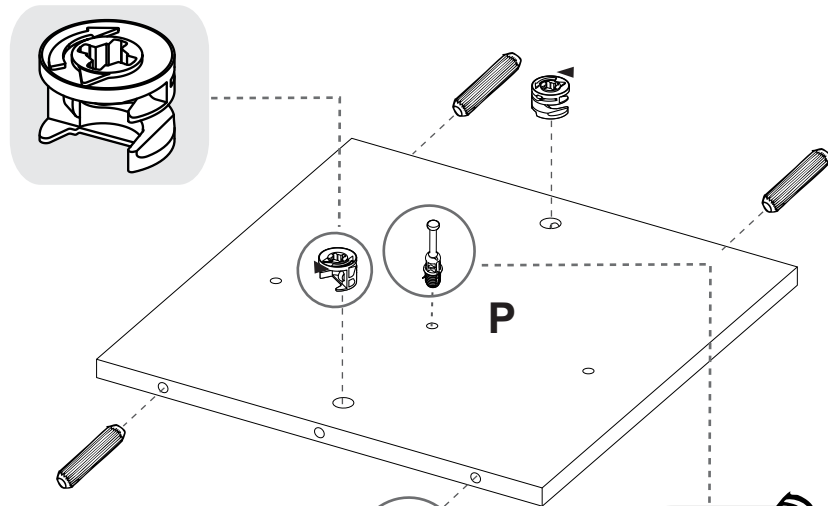

1 Gota x perforación
/ 1 drop

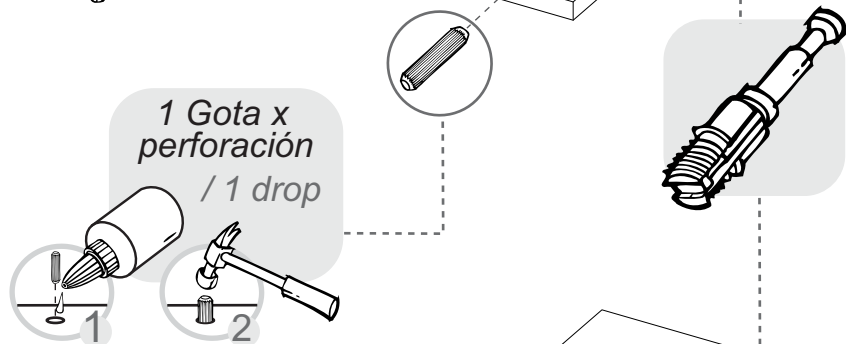

18

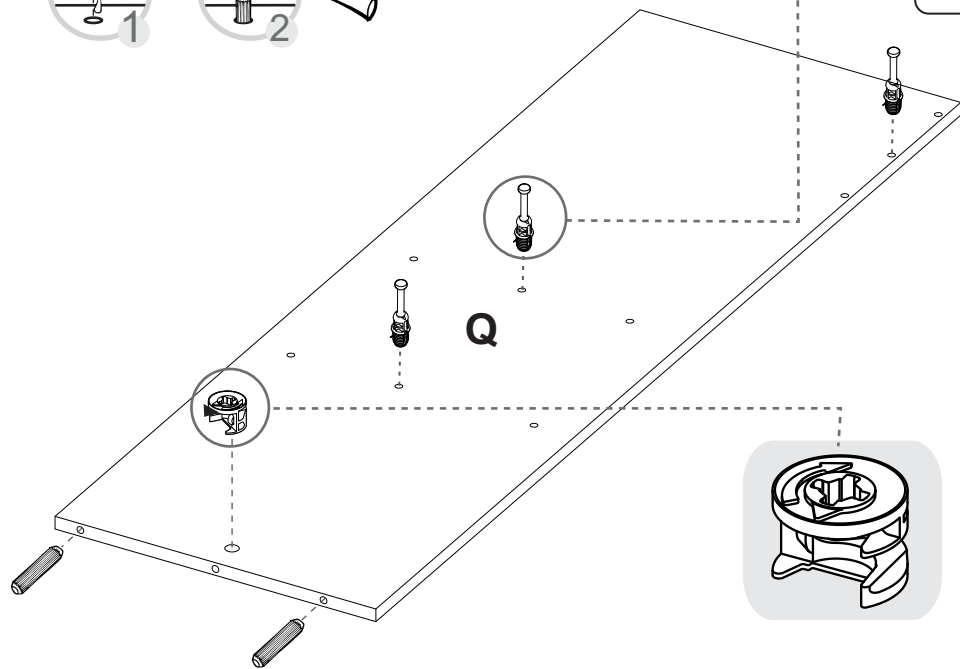

19



Revisar que el **tope plástico** del riel quede en la **PARTE TRASERA**/
The plastic stop should be placed on the rear.

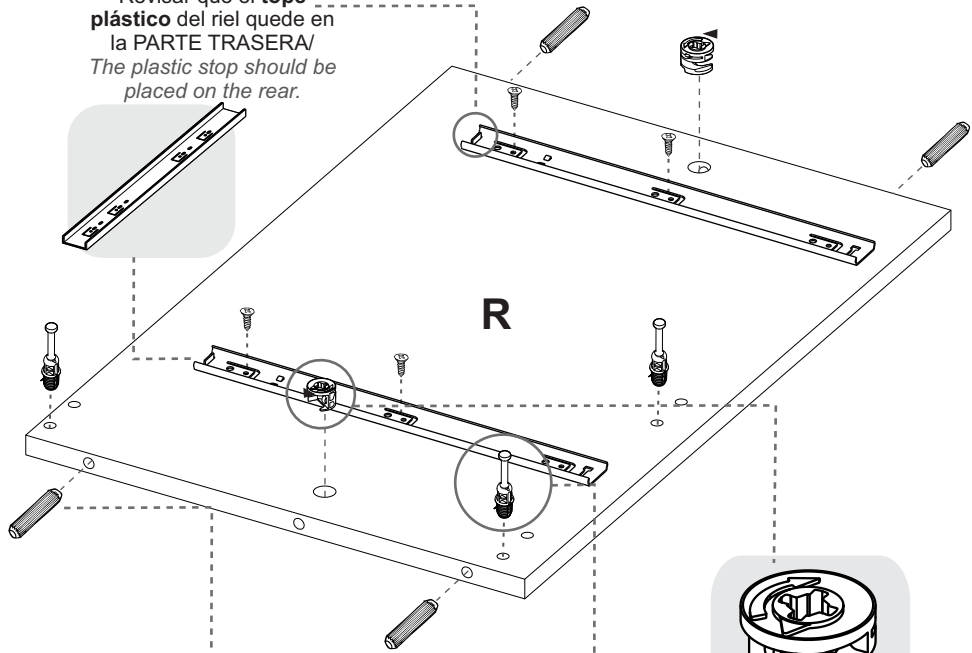

20

1 Gota x perforación / 1 drop

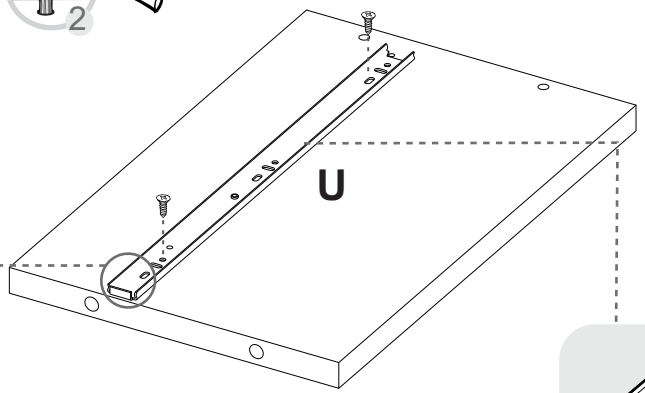
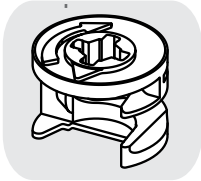
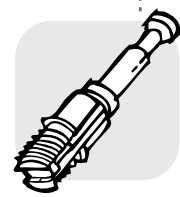
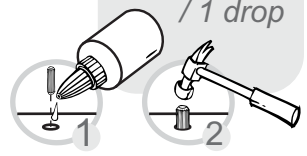

Revisar que el **tope metálico** del riel quede en la **PARTE DELANTERA**/
The metallic stop should be placed on the front.

21

VOLTEAR
TURN OVER

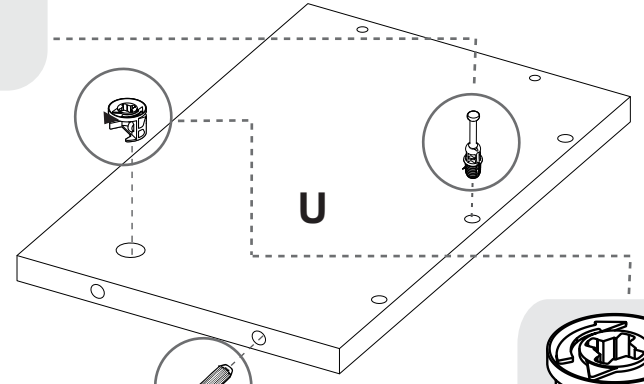
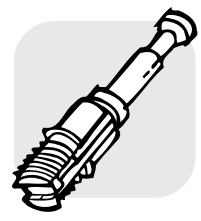

1 Gota x perforación / 1 drop

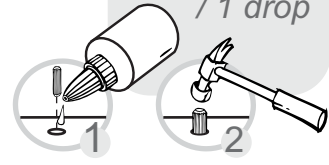

22

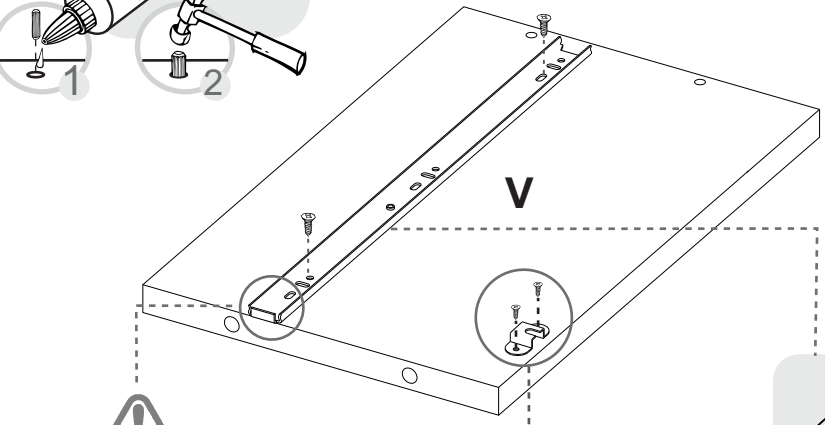

Revisar que el **tope metálico** del riel quede en la **PARTE DELANTERA**/
The metallic stop should be placed on the front.

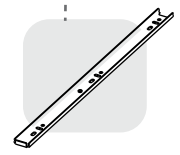

16

Deslice los cajones dentro del mueble / Slide the drawers inside the cabinet

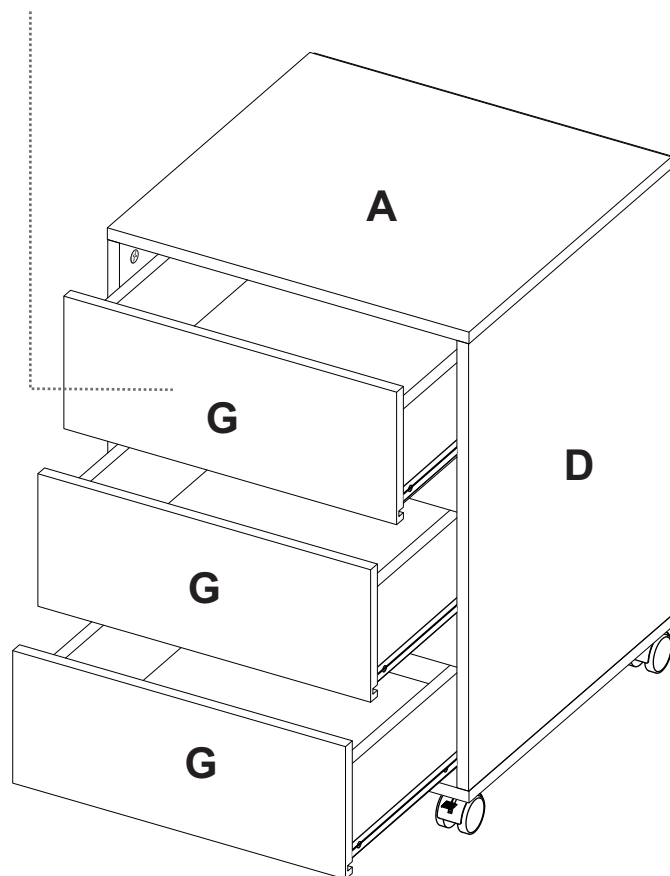

Al finalizar el ajuste de los conectores, proceda a poner las tapas adhesivas / When you finish the adjustment of the connectors, proceed to put the cover tapes



Al terminar de armar despegue los adhesivos (en caso de que queden residuos de pegamento, limpie la superficie con alcohol) / When you finish off adhesive build (in case of residues of glue, wipe it with alcohol)

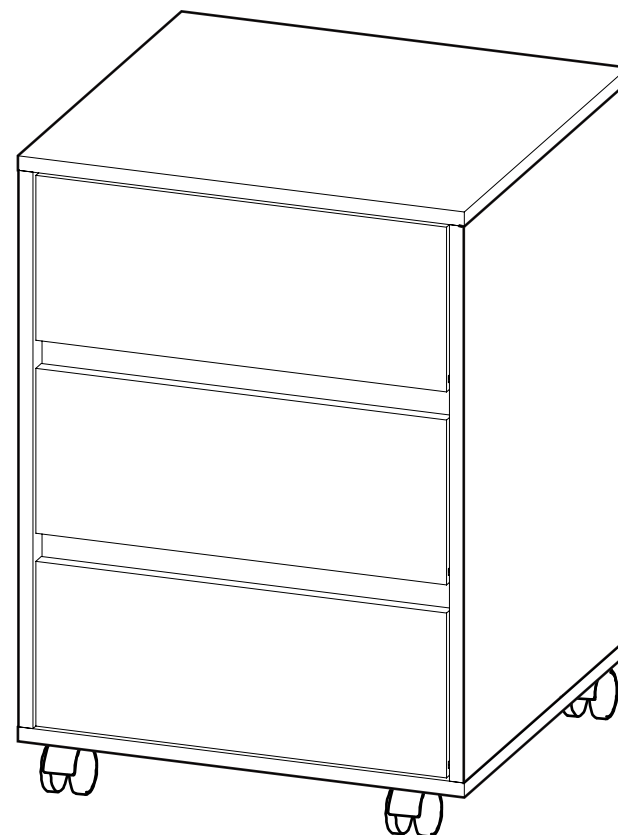

Alto/ Height: 66 cm / 25.98 in
Ancho/ Width: 46,4 cm / 18.26 in
Fondo/ Depth: 45,3 cm / 17.83 in

LOTE No: _____

REF./SKU. CLW3304 - CLH3305

By: **RTA**® TEL (572) 691 17 00
m u e b l e s PBX (572) 695 91 81
CALI - COLOMBIA
www.rta.com.co

CAJONERA OFFICE
/OFFICE Drawers File Cabinet

RECOMENDACIONES IMPORTANTES KEY RECOMMENDATIONS

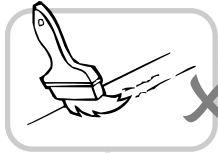

NO pinte el mueble /
Do not paint the
furniture.



NO mojar o ubicar
a la intemperie /
Do not expose to rain
or direct sun.

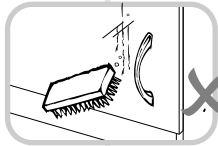
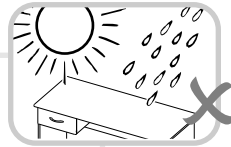

NO lavar las manijas o
tiraderas con jabones o
elementos abrasivos /
Do not wash handles or
drawers with soap or
abrasives.

NO sobrecargue el mueble.
no exceda el peso de 30 kilos
para gabinetes de cocina /
Do not overload the cabinet.
Weight max. 66lbs
for kitchen cabinets.

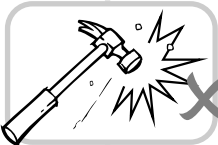

NO golpear ni martillar
el mueble (hágalo sólo
donde se indique) /
Do not hit or hammer
the furniture (just do it
where is indicated).

NO permita que los niños
manipulen el mueble, puede
voltearse y lastimarlos /
Do not allow children to
handle the cabinets or
drawers, they could get hurt.

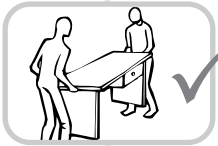
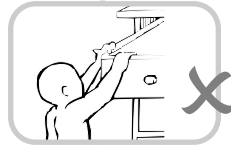

SIEMPRE levante el
mueble entre dos
personas, NO lo arrastre /
Do not drag the furniture.
Lift it between two people.

Limpie con paño seco,
/ Clean with a dry cloth.



HERRAJES BÁSICOS PARA MUEBLES RTA BASIC HARDWARE FOR RTA FURNITURE

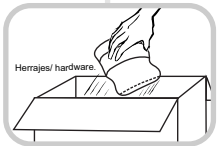

1. Abrir la caja del mueble
y buscar la bolsa con los
herrajes / Open the box
and look for the hardware
bag.

3. Separe los herrajes para
facilitar su identificación
durante el armado /
Separate hardware for easy
identification during
assembly.

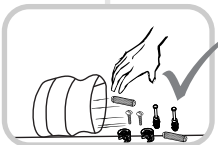
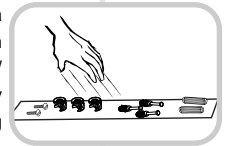

2. Abrir el paquete y
comprobar que el
contenido de las piezas es
correcto / Open the
package and verify that
the content of the pieces
is correct.

4. Arme el mueble en un lugar
limpio y en una superficie
plana / RTA furniture
must be assembled
in a clean place and on
a flat surface.

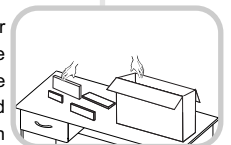

PARA PONER RIEL EN LATERAL DEL MUEBLE:

Revisar que el **tope
plástico** del riel quede en
la **PARTE TRASERA** /
The plastic stop should be
placed on the rear.

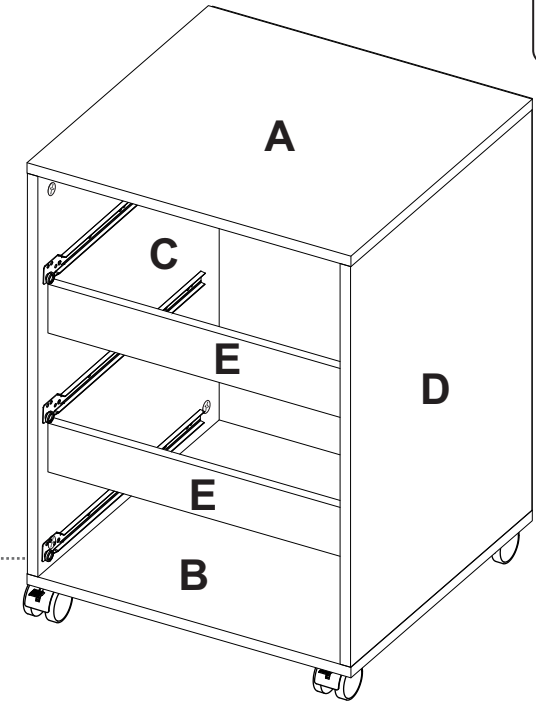
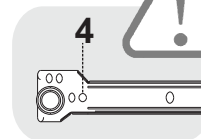
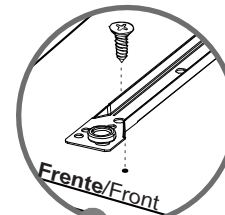

14



IMPORTANTE

Voltear el mueble cuidadosamente para ensamblar el fondo /
Be careful turning over the cabinet

15

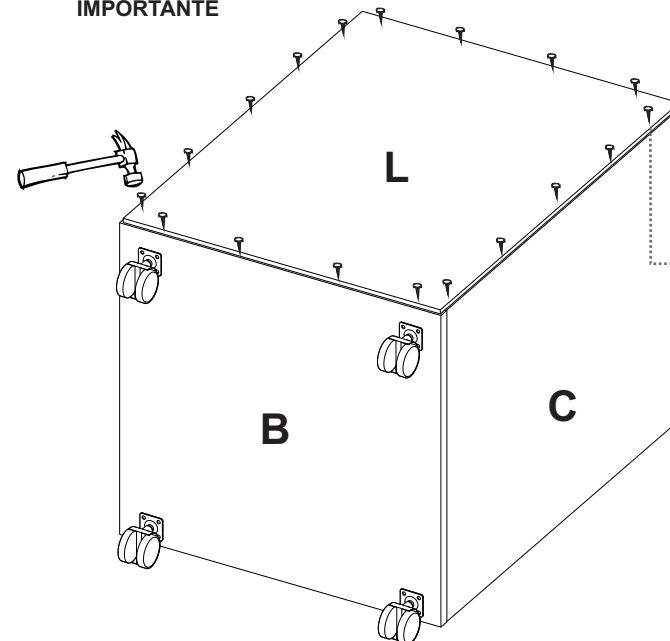



Girar 180° /
Rotate 180°

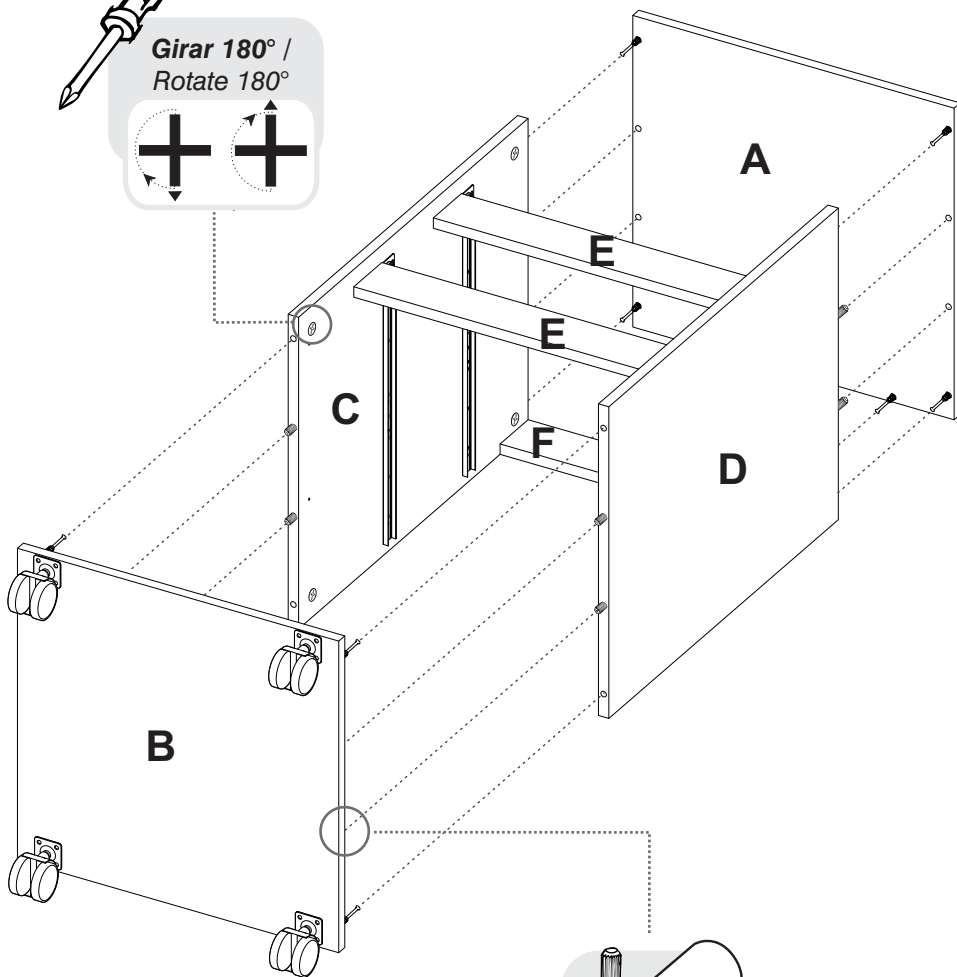
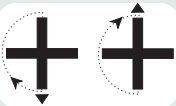

RECOMENDACIONES DE ENSAMBLE / ASSEMBLY RECOMMENDATIONS

El buen funcionamiento del mueble depende de un adecuado ensamblaje
An excellent furniture's performance relies on a solid and a suitable assembly.

MINIFIX / CONNECTOR - DOWELS

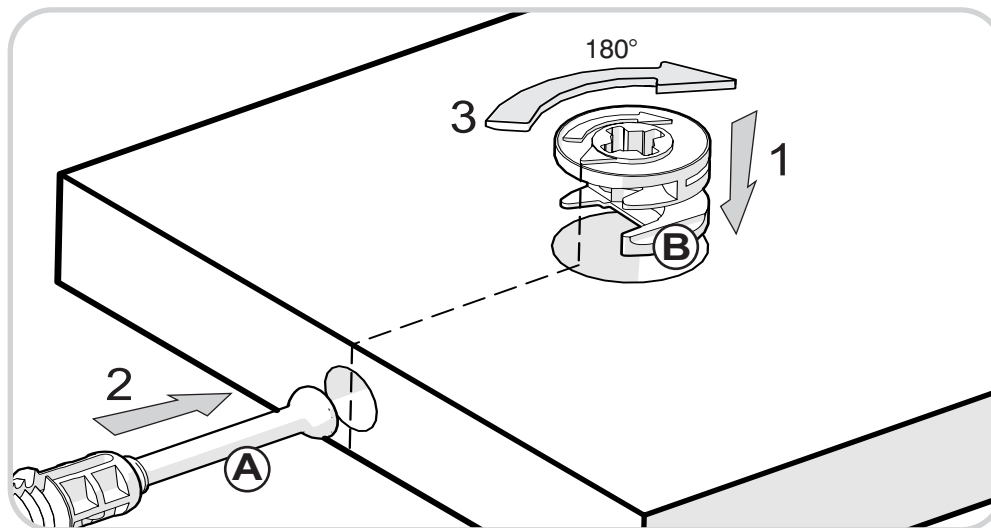

Sistema de unión compuesto por un perno (A) y una caja minifix (B).

(1) Se inserta la caja minifix dentro de la perforación ubicada en la cara de la pieza, la flecha debe apuntar siempre a la dirección de la perforación por donde entrará el perno.

(2) Se debe insertar el perno por su parte plástica en las perforaciones que se indiquen, luego se inserta la punta metálica en la perforación para que su cabeza quede al interior de la caja minifix.

(3) Girar la caja minifix 180° para apretar las dos piezas.

It's a fitting system made of a spreading bolt (A) and a minifix cam (B).

(1) Insert the minifix cam in the hole placed in the face of the panel with the arrow pointing towards the hole where the bolt will fit.

(2) Insert the bolt with its plastic base in the shown holes, then insert the metallic bolt head in the holes so it fits inside the minifix cam.

(3) Tight the panels by turning the minifix cam 180°.

TARUGOS O TAQUETES / FLUTED DOWEL PIN

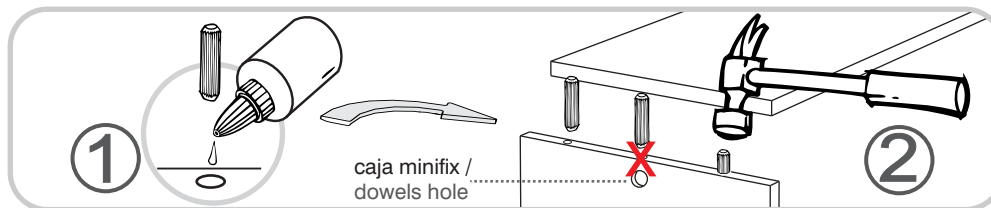

Es un pedazo de madera corto y grueso, de aproximadamente 5 a 10 cm de largo, que sirve para amarrar el mueble y darle resistencia. Tenga en cuenta que debe aplicar una gota de pegamento en cada perforación en la que se pondrá el taquete.

It's a short and thick piece of wood, 1,9 to 3,9 inches approximately, which is used to tie the cabinet and give it resistance. Take into account to apply a drop of glue on each hole you will insert the fluted dowel pin.

RECOMENDACIONES IMPORTANTES / KEY RECOMMENDATIONS

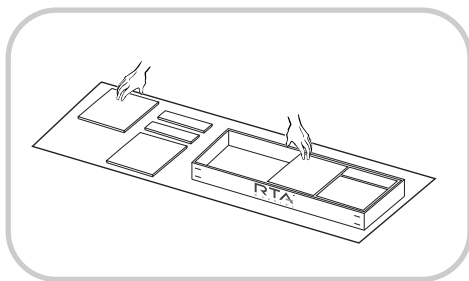

Se recomienda armar el mueble sobre la caja o una superficie lisa para no rayarlo. It is recommended to assemble the product on the box or on a flat surface to not scratch it.

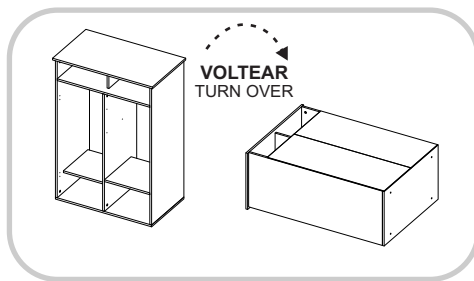

Voltear el mueble cuidadosamente para ensamblar los fondos. Carefully turn over the cabinet to assemble the back panels.

PESO MAX. SUGERIDO EN MUEBLE (Kg) / MAX SUGGESTED LOAD (Kg)

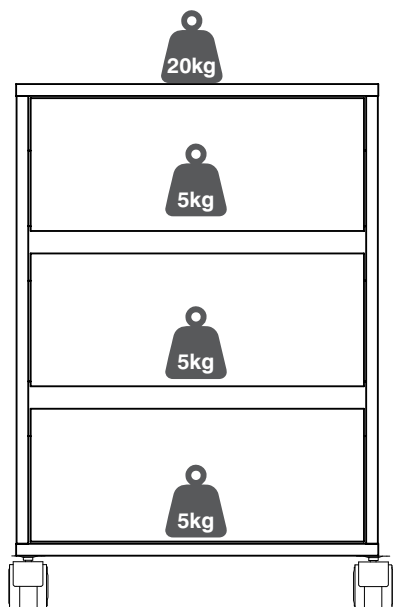

NOTA: La resistencia a las cargas puede variar dependiendo si es una carga distribuida o una carga puntual, las gráficas corresponden a cargas puntuales, NO exceder los pesos sugeridos / **NOTE:** The load capacity depends if it is a *point load* or if it is an *uniform distributed load*, do not exceed the suggested loads.

11



Girar 180° / Rotate 180°

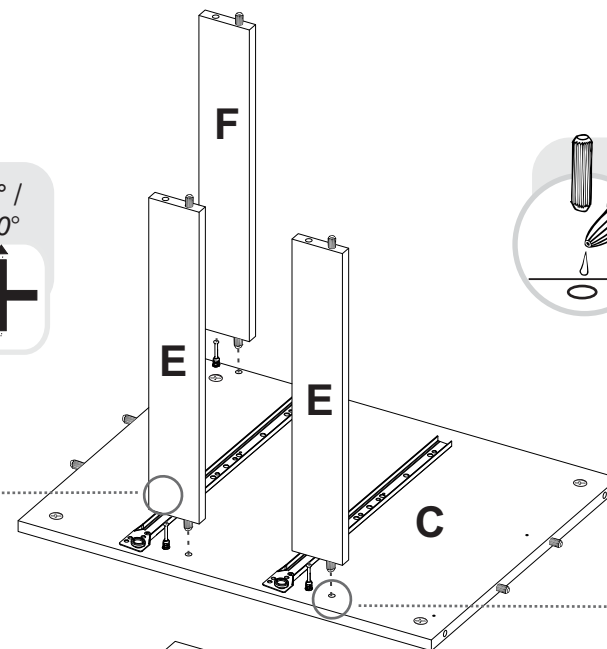
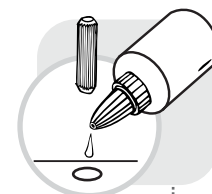
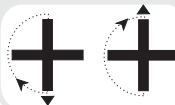

12

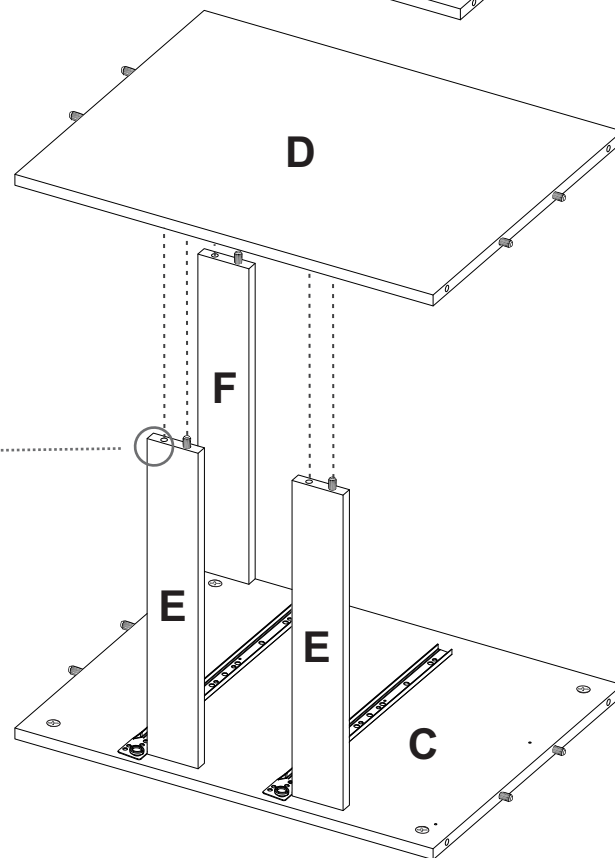

9



Girar 180° /
Rotate 180°

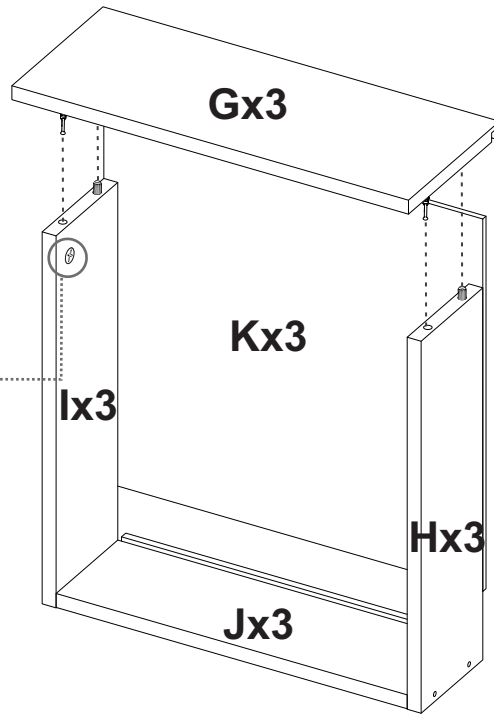
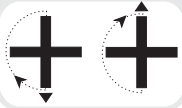

10

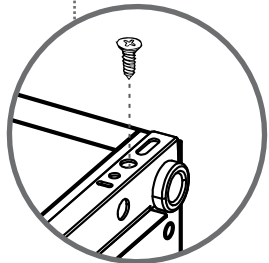
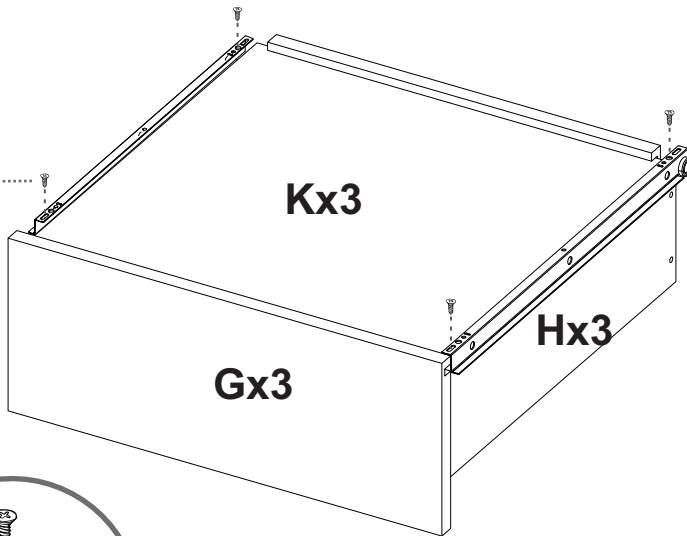

**Repetir estos pasos con las
piezas de los otros cajones /
Repeat these steps with the other
drawers**

HERRAJES PARA ARMADO ASSEMBLY HARDWARE

x22



Tarugo/
Fluted Dowel Pin

x22



Perno minifix/
Spreading Bolt

x22



Minifix/
Minifix Cams

x22



Tapa Adhesiva
Minifix/ Cover Caps

x2

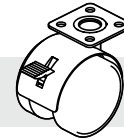

Rodachina con Freno/
Wheel Caster with
Brake

x2

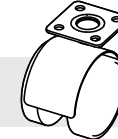

Rodachina/
Wheel Caster

x1



Pegante/
Glue

x3



Riel/
Drawer Slide

x12

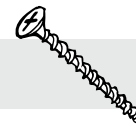

Tornillo Ensamble 2"/
Assembly Screw

x40



Tornillo lámina
6 X 9/16"/
Sheet Metal Screw

x18



Puntilla/
Nail



TENER PRECAUCIÓN AL ABRIR LA BOLSA DE HERRAJES PARA NO EXTRAIAR NINGUNO. COMPRUEBE QUE EL CONTENIDO DE LAS PIEZAS SEA EL CORRECTO. EN CASO QUE FALTE ALGUNA PIEZA O ESTE DEFECTUOSA DEVUELVA LAS PIEZAS AL ALMACÉN CON SU FACTURA PARA EFECTUAR EL CAMBIO DE LAS PIEZAS Y/O LOS HERRAJES LO MÁS PRONTO POSIBLE. / PLEASE BE CAUTIOUS WHEN OPENING THE HARDWARE BAG TO NOT LOSE ANY. CHECK THE CONTENTS OF THE PARTS ARE CORRECT. IF ANY PART IS MISSING OR IMPERFECT PLEASE RETURN THE PARTS TO THE STORE WITH THE PRODUCT INVOICE ATTACHED TO MAKE EFECTIVE THE REPLACEMENT OF THE IMPERFECT PIECES OR HARDWARE AS SOON AS POSSIBLE.

PIEZAS DE ARMADO ASSEMBLY PARTS

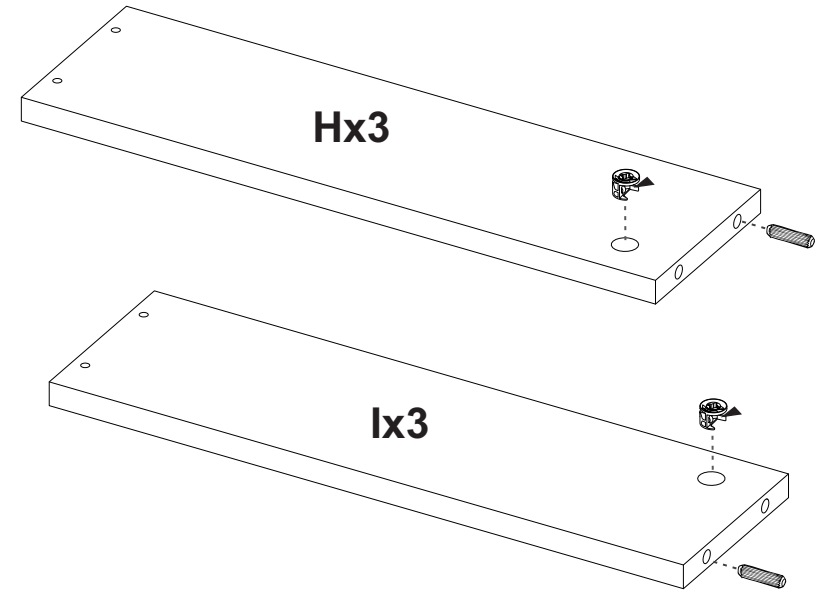
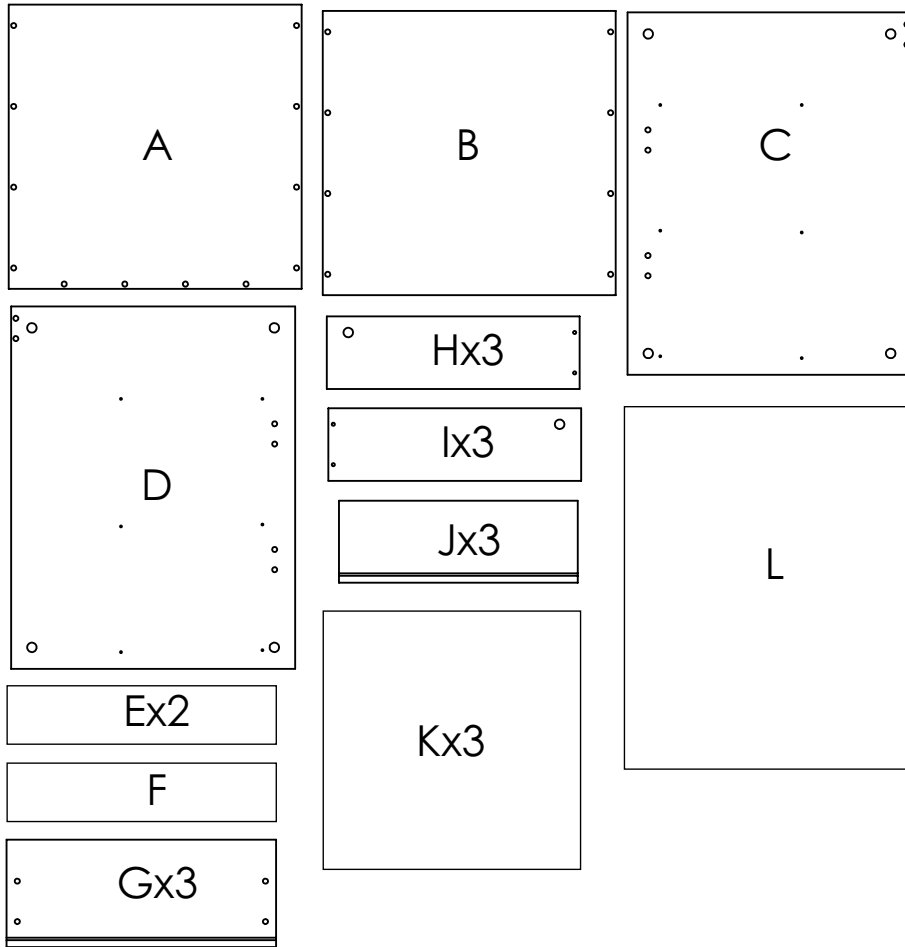

7

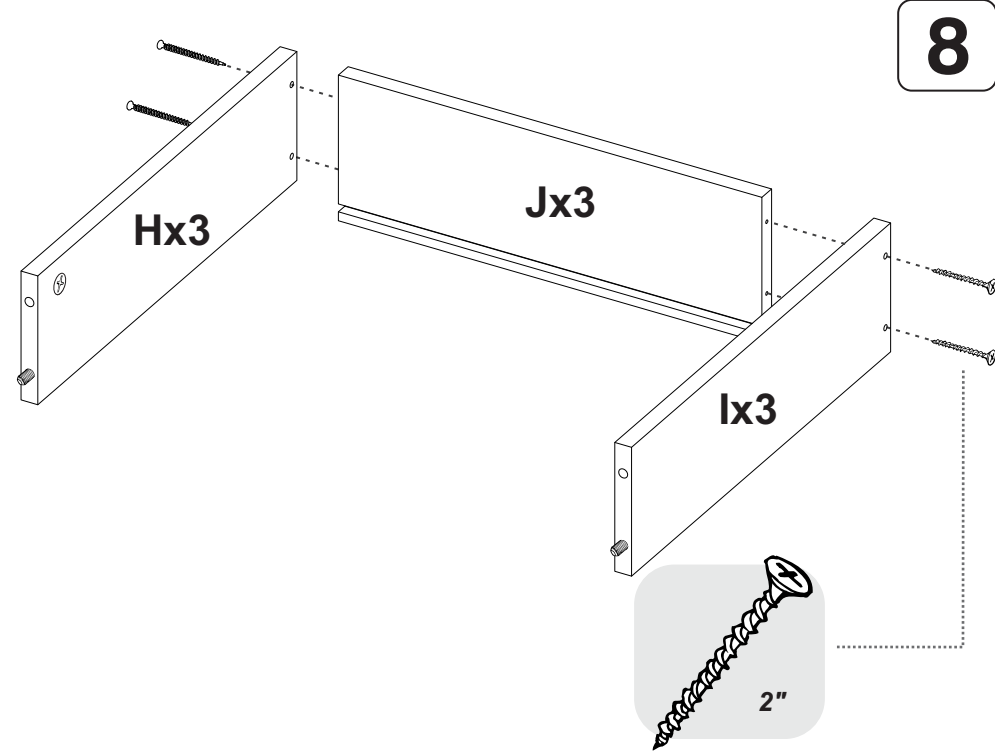

8



ANTES DE EMPEZAR A ARMAR EL MUEBLE LEA DETENIDAMENTE LAS INSTRUCCIONES. SE RECOMIENDA ARMAR EL MUEBLE SOBRE LA CAJA O SOBRE UNA SUPERFICIE LISA Y CUBIERTA, PARA NO RAYARLO / BEFORE STARTING TO ASSEMBLE THE CABINET, CAREFULLY READ THE INSTRUCTIONS. IT IS RECOMMENDED TO ASSEMBLE THE FURNITURE ON THE BOX OR ON A FLAT AND COVERED SURFACE IN ORDER TO NOT SCRATCH THE PRODUCT.

5

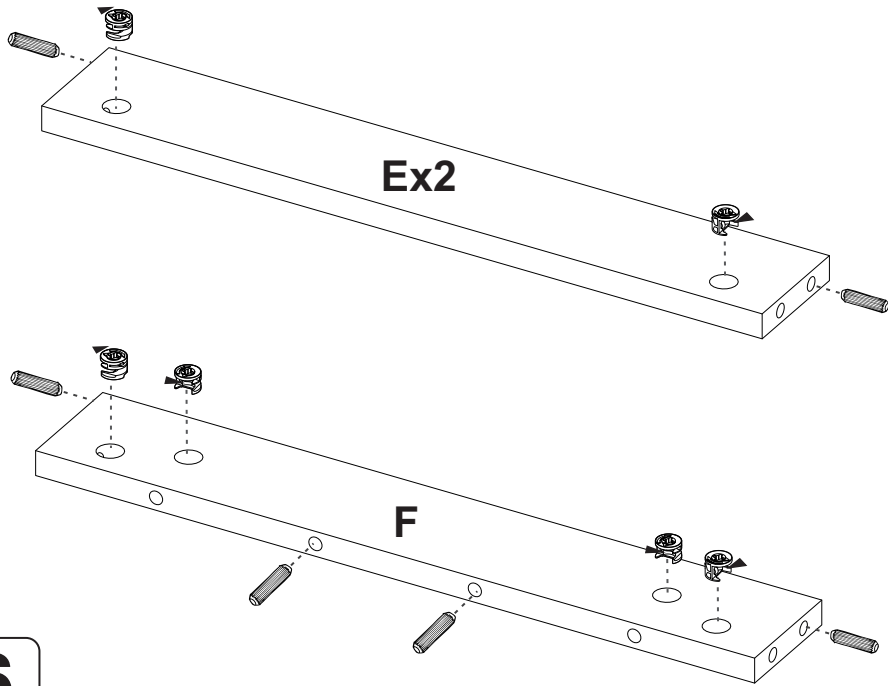

6

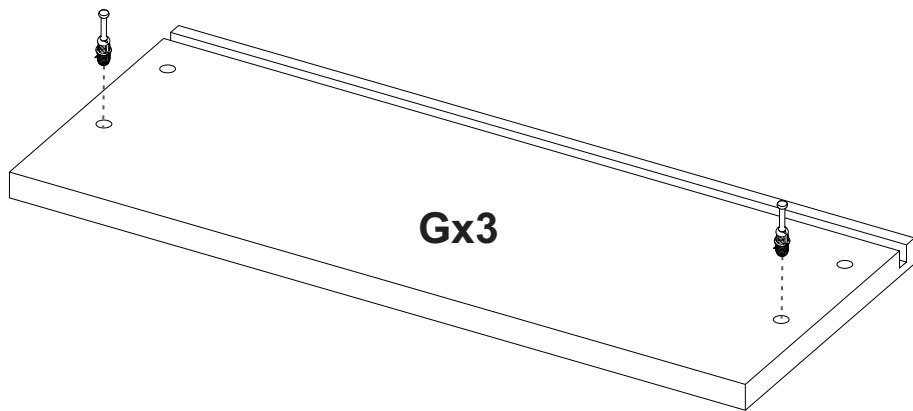

*

*(Herramientas NO incluidas) / (Tools not included)

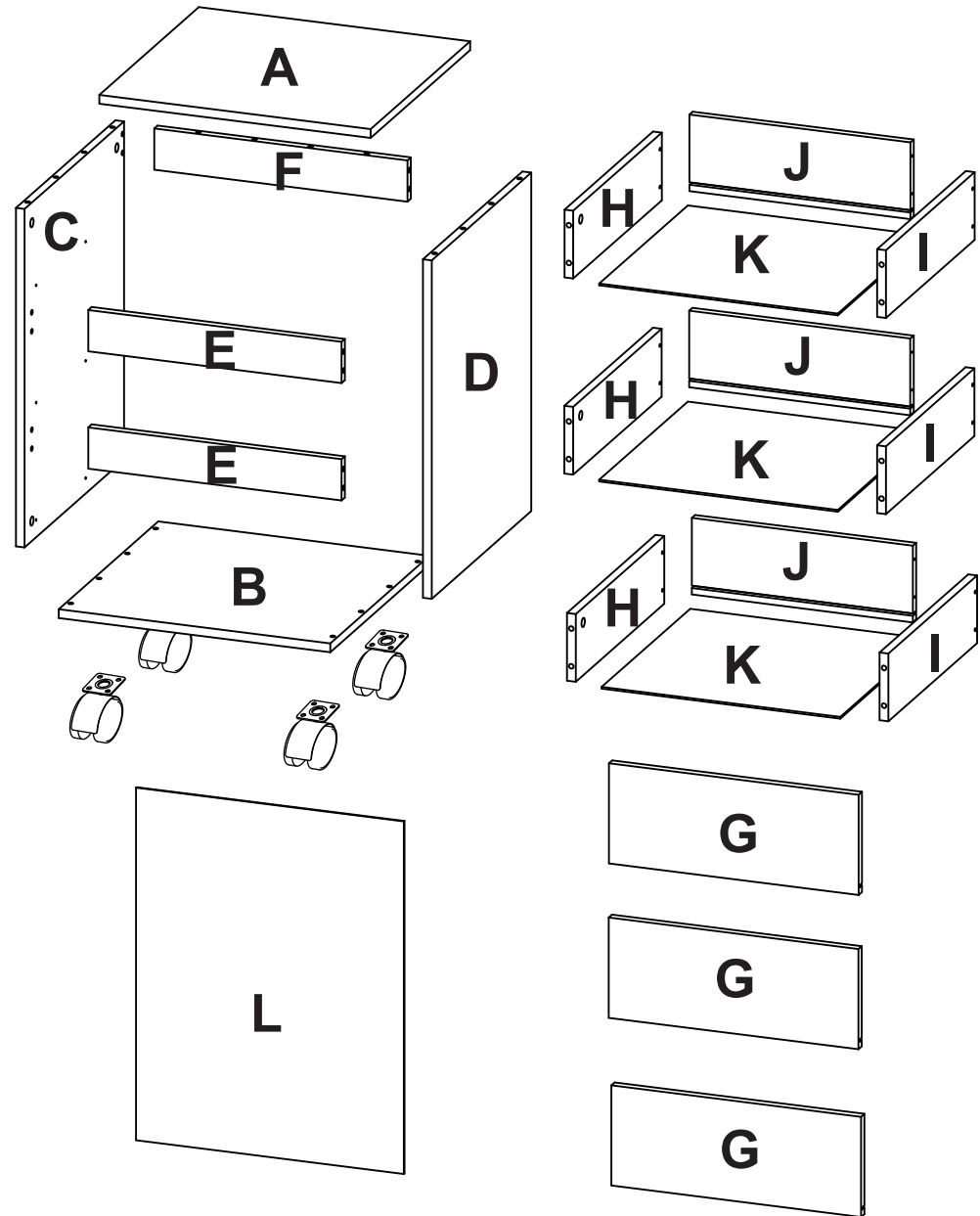

1

SE RECOMIENDA ARMAR EL MUEBLE ENTRE DOS PERSONAS /
IT IS RECOMMENDED TO ASSEMBLE THE PRODUCT BETWEEN TWO PEOPLE

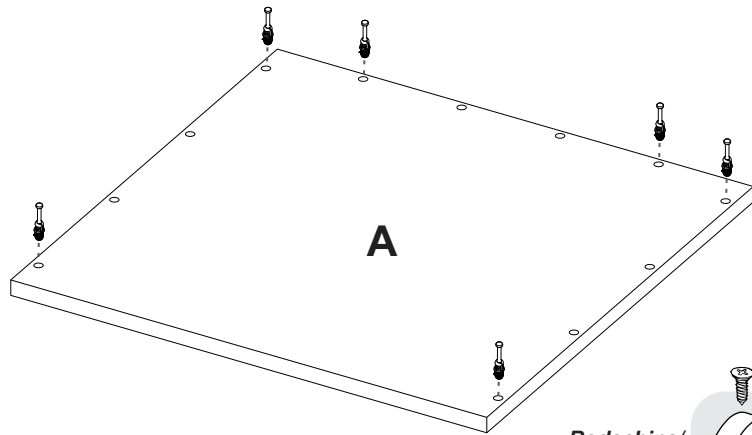
**A**

Rodachina/
Wheel caster

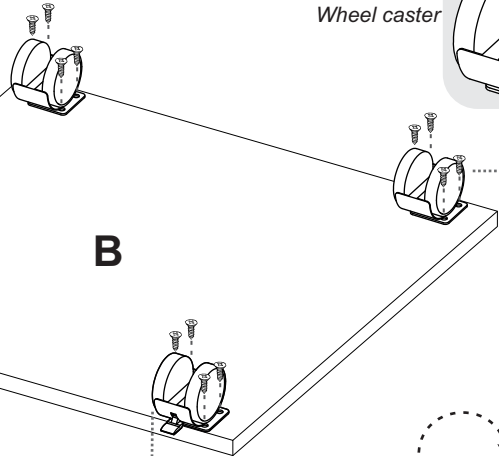
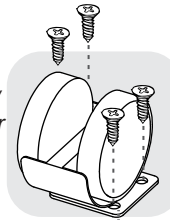
**B**

VOLTEAR/
TURN OVER

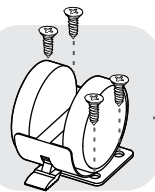

Rodachina con
freno/
Wheel caster
with brake

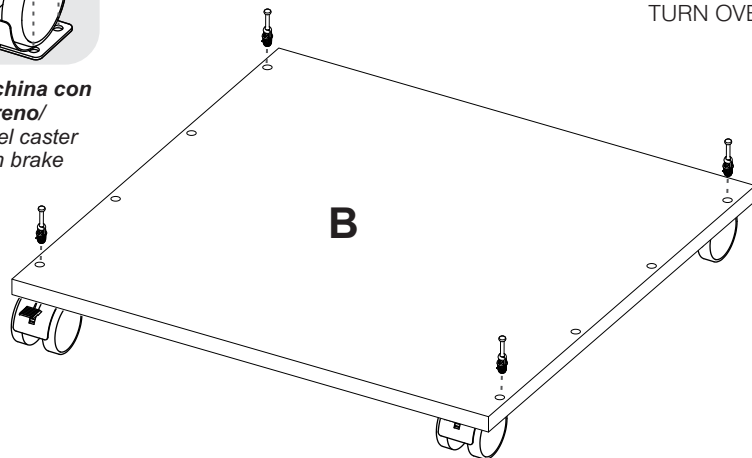
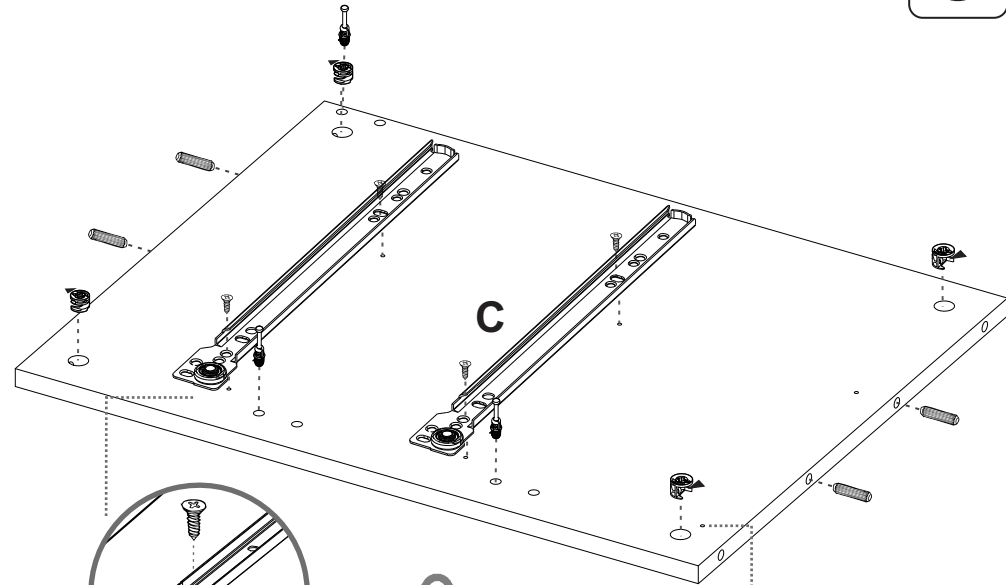
**B****3****C**

Frente/Front

4

Instalar en el paso 14/
Install on step 14

Instalar en el paso 14/
Install on step 14

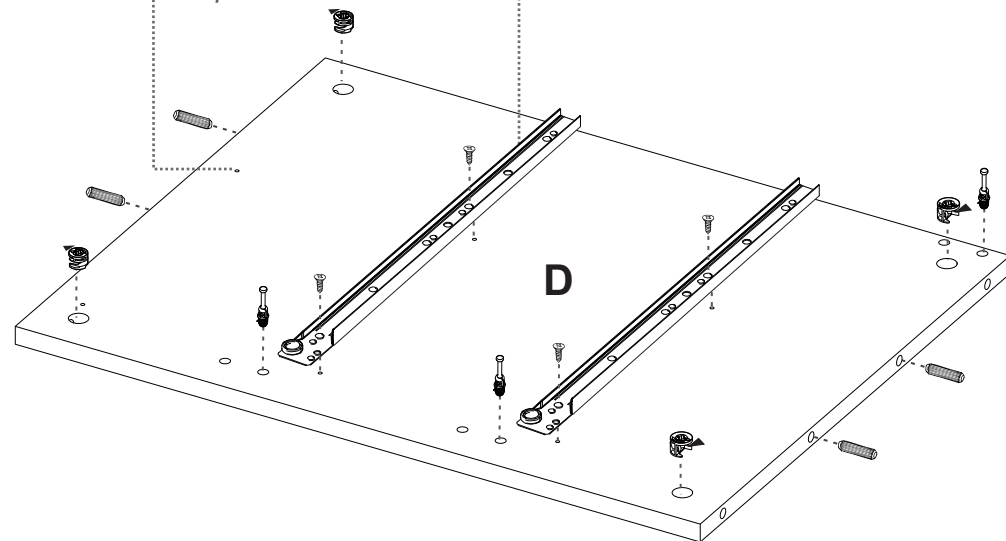
4**D**